



Quest Elite 2000 2-Flavor Post-Mix Dispenser

Specification Sheet



Features

Wide Product/Ratio Capability

Dispense juices and lemonades with pulp, teas, plus cold coffees within a 3:1 to 8:1 ratio

Patented Mixing System

Consistent quality drinks with no stratification, slugging, or dripping

Frost-free Refrigeration

Safely accommodate frozen, ambient, or aseptic concentrate BIBs and cartridges

Large Ice Bank

Six to eight-pound cooling capacity ensures cold drinks during peak demand

Optional Touchless Dispense Kit

Hygienic, touch-free dispense conversion kit available

LED Illuminated Graphic

Attract attention while reducing energy and maintenance cost with the eye-catching backlit merchandiser

Flexible Merchandiser

Choose from a single or multi-panel display with a variety of included graphics

'Sold Out' Indicator

Prevent missed sales with product-out alerts

Easy to Service

Modular components and accessible cabinet design for ease of service

Narrow Footprint

Minimized size to maximize counter space



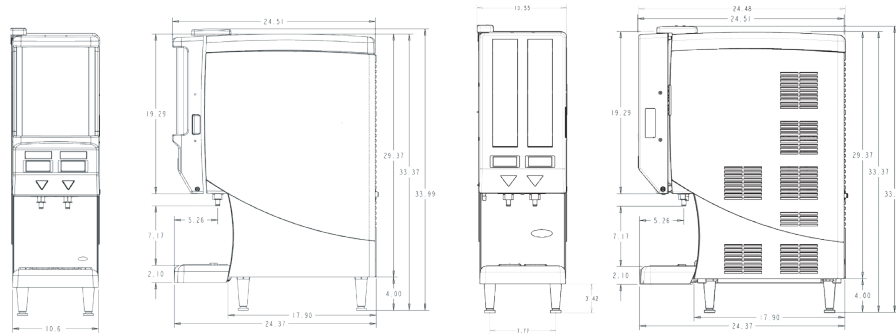

Quest Elite 2000 2-Flavor Post-Mix Dispenser

Specification Sheet



Technical Specifications

Electrical	115V/60Hz, 230V/50Hz
Refrigerant	R290 refrigerant (56g) hermetically sealed
Ice Bank Size	6-8 lbs.
Operating Conditions	40oF to 100oF (4.4o C to 37.8oC)
Interior Cabinet Dimensions	7.5"W x 9.5"D x 9.0"H (19.5 cm x 24.1 cm x 22.9 cm)
Dispenser Dimensions	10.6"W x 25.0"D x 34.0"H (26.9 cm x 63.5 cm x 86.4 cm)
Recommended Clearance	Top: 12.0" (30.5 cm) Back: 4.0" (10.2 cm) and Sides: 4.0" (10.2 cm)
Weight	Dry: 104 lbs. (47.2 kg) Operating: 136 lbs. (61.7 kg) Shipping: 120 lbs (54.4 kg)
Merchandise Graphic Size	Single Panel: 11.7"W x 11.1"H (29.7 cm x 28.1 cm) Multi-Panel: 2.9"W x 13.0"H (7.4 cm x 33.9 cm)

Post-Mix Ratio	3:1, 4:1, 5:1, 6:1, 7:1, 8:1
Drinks Per Minute	Three 12 oz drinks/min (355 mL) up to 100 drinks @ 750F (240C) ambient, 750F (240C) incoming water, and 410F (50C) concentrate w/o exceeding 400F (4.40C).
Concentrate Storage	2 - 3.5L bottles
Water Connection	3/8" SAE male flare fitting on dispenser
Water Supply Requirements	Optimum Pressure: 50psi (3.4 bar) flowing 3oz/sec Minimum Static Pressure: 30psi (2.1 bar) Maximum Static Pressure: 60psi (4.1 bar)
	<i>For water pressure exceeding the optimum supply specification, flow control set at 50psi is recommended</i>
Flow Rate	Beverage pour rate 1-2.2oz/sec
Agency Listing QST ELITE 2290 QST ELITE 2290 W	  

Part Number	Description
721Q02101JU1	Quest Elite R290 SLJ 2 flavor, illuminated, non-flush, push button 115V/60, single-panel merchandiser
721Q02101JU2	Quest Elite R290 SLJ, 2 flavor, illuminated, non-flush, push button 115V/60, multi-panel merchandiser
721Q14101JU1	Quest Elite R290 SLJ, 2 flavor, illuminated, flush portion control, 115V/60, single-panel merchandiser
721Q12101JU1	Quest Elite R290 SLJ 2 flavor, illuminated, flush, push button 115V/60, single-panel merchandiser
721Q25111JU1	Quest Elite R290 SLJ 2 flavor, illuminated, flush, push button 230V/50, single-panel merchandiser
721Q25112JU1	Quest Elite R290 SLJ, 2 flavor, illuminated, flush, portion control, 230V/50, single-panel merchandiser
721Q25312JU1	Quest Elite R290 QLT, 2 flavor, illuminated, portion control, 230V/50, single-panel merchandiser
721422511DE1	Quest Elite R290 QLT, 2 flavor, illuminated, portion control, 230V/50, single-panel merchandiser
721422511DE2	Quest Elite R290 QLT, 2 flavor, illuminated, portion control 230V/50, multi-panel merchandiser
720401107	3.5 L Refillable Concentrate Reservoir
729011126	Bag-In-Box Option Kit
729011183	Extender Nozzle Kit
729011004	Tall Cup Adapter Kit - 2 Flavor
629097998	Touchless Dispense Kit - 2 Flavor
729011218	Portion Control Kit - 2 Flavor
629097144	ADA Installation Kit - 2 Flavor

To learn more about **Quest Elite**, visit cornelius.com