

ICE DIVERTER ED/DF DISPENSER KIT

P/N 02394

INSTALLATION MANUAL

Release Date: August 25, 2004

Publication Number: 92303INS

Revision Date: March 27, 2014

Revision: F

Visit the Cornelius web site at www.cornelius.com for all your Literature needs.

The products, technical information, and instructions contained in this manual are subject to change without notice. These instructions are not intended to cover all details or variations of the equipment, nor to provide for every possible contingency in the installation, operation or maintenance of this equipment. This manual assumes that the person(s) working on the equipment have been trained and are skilled in working with electrical, plumbing, pneumatic, and mechanical equipment. It is assumed that appropriate safety precautions are taken and that all local safety and construction requirements are being met, in addition to the information contained in this manual.

This Product is warranted only as provided in Cornelius' Commercial Warranty applicable to this Product and is subject to all of the restrictions and limitations contained in the Commercial Warranty.

Cornelius will not be responsible for any repair, replacement or other service required by or loss or damage resulting from any of the following occurrences, including but not limited to, (1) other than normal and proper use and normal service conditions with respect to the Product, (2) improper voltage, (3) inadequate wiring, (4) abuse, (5) accident, (6) alteration, (7) misuse, (8) neglect, (9) unauthorized repair or the failure to utilize suitably qualified and trained persons to perform service and/or repair of the Product, (10) improper cleaning, (11) failure to follow installation, operating, cleaning or maintenance instructions, (12) use of "non-authorized" parts (i.e., parts that are not 100% compatible with the Product) which use voids the entire warranty, (13) Product parts in contact with water or the product dispensed which are adversely impacted by changes in liquid scale or chemical composition.

Contact Information:

To inquire about current revisions of this and other documentation or for assistance with any Cornelius product contact:

www.cornelius-usa.com

800-238-3600

Trademarks and Copyrights:

This document contains proprietary information and it may not be reproduced in any way without permission from Cornelius.

This document contains the original instructions for the unit described.

CORNELIUS INC
101 Regency Drive
Glendale Heights, IL
Tel: + 1 800-238-3600

Printed in U.S.A.

NOTE: For dispensing Scotsman NME654, NME954 and NME 1254 “Nugget” style ice and Cornelius WCC500 and WCC700 “Chunklet” style ice cubes.

⚠ WARNING:

Disconnect power to the unit before servicing. Follow all lock out/tag out procedures established by the user. Verify all power is off to the unit before performing any work.

Failure to comply could result in serious injury, death or damage to the equipment.

Perform the following procedure:

1. Remove upper front panel/merchandiser from dispenser.
2. Remove ice chute portion and gate restrictor.
3. Install ice diverter as shown (see Figure 1) and reinstall the gate restrictor removed in previous step. Gate restrictor should be installed in ‘front’ of ice diverter .

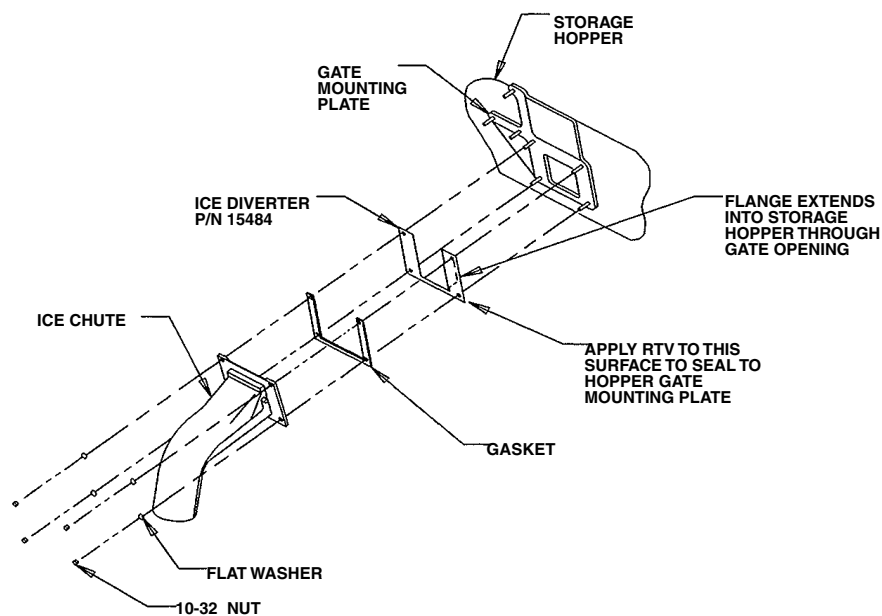

Figure 1. Exploded View of Ice Diverter Installation

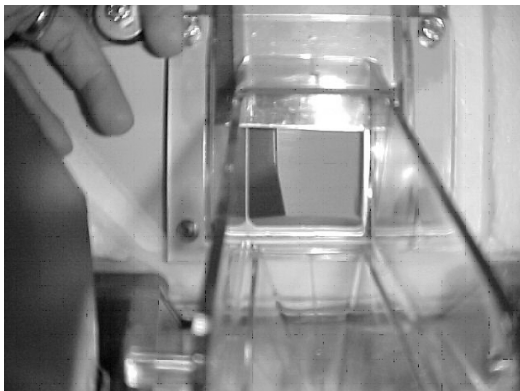

Figure 2. Gate Restrictor Full Opening

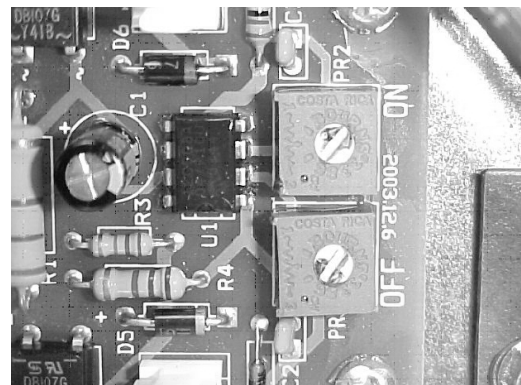

Figure 3. Timer Board Settings Reset

4. Remove screws securing white reflector panel and gain access to electrical box. Locate timer board and reset agitation timer to 0.5 seconds ‘ON’ and 3 hours ‘OFF’ (see Figure 3).
5. Re-install front panel and plug unit back into outlet.
6. Unit should now be ready to dispense ice for customer use.

Cornelius Inc.
www.cornelius.com