



## **20 SERIES**

ICE STORAGE BINS



### **FEATURES**

**Durable** - One piece rotomolded cabinet

**High impact** - Polyethylene liner

**Long lasting** - Corrosion proof

**Heavy Duty** - Stainless steel door

**Environmentally responsible** - Non-CFC foam insulation

**DIMENSIONS**

UNIT	A	B	C	D	E	F	G	H
B322	22" (56 cm)	27.62" (70 cm)	42" (107 cm)	6" (15 cm)	31.75" (81 cm)	0.75" (2 cm)	2.75" (7 cm)	11" (28 cm)

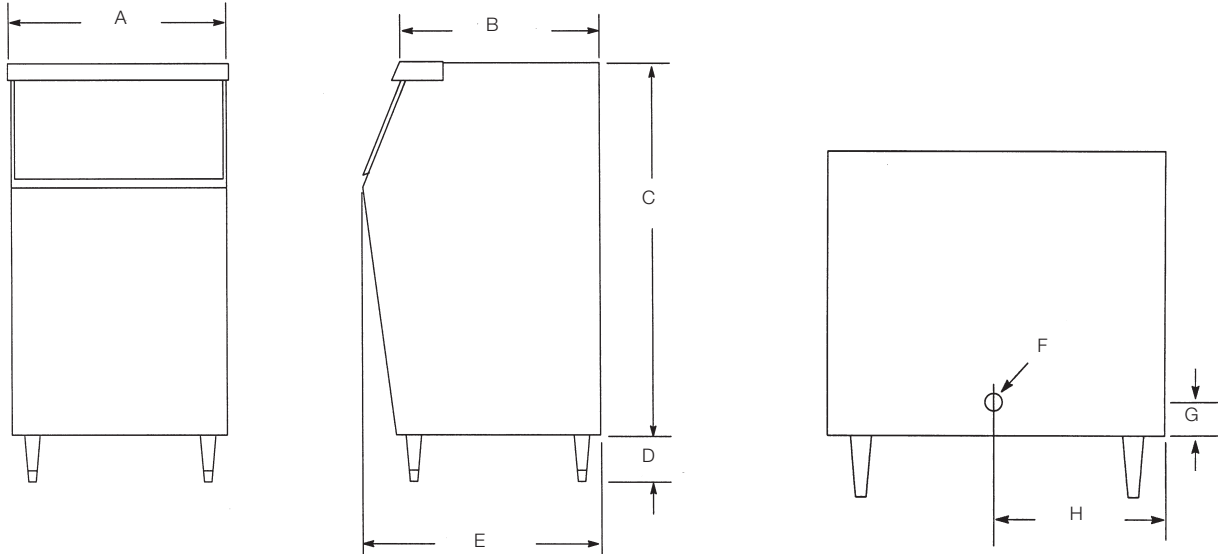

PART NUMBER	ARI CERTIFIED CUBE STORAGE CAPACITY*	ICE APPLICATION STORAGE CAPACITY	EMPTY WEIGHT	SHIPPING WEIGHT
B322AP	260 lb (118 kg)	300 lb (136 kg)	80 lb (36 kg)	90 lb (41 kg)

\* Certified in accordance with ARI Standard 820-88

**TECHNICAL SPECIFICATIONS**

**DRAIN CONNECTION** . . . . . 0.75" (2 cm) female fitting can be adapted to plastic, copper or galvanized drain line

**CABINET FINISH** . . . . . One piece gray polyethylene exterior and interior, stainless steel door

**WARRANTY** . . . . . 1 year parts and labor

**AGENCY LISTINGS** . . . . .

