

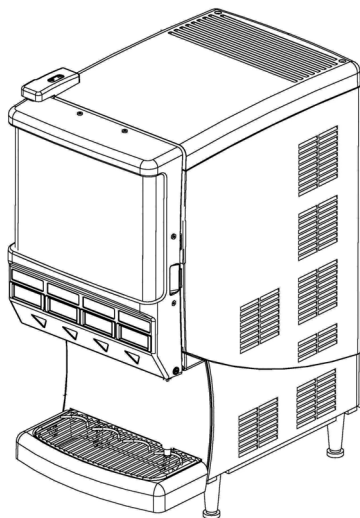

QUEST ELITE 4000

Installation And Operator Manual



QUEST ELITE 4000

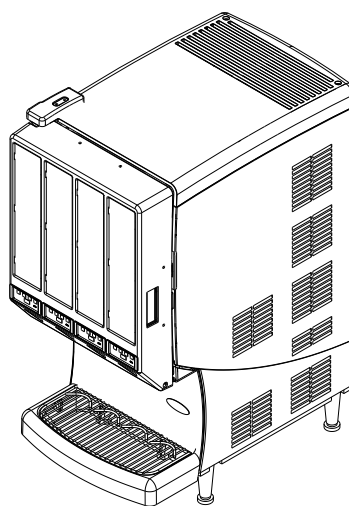

QUEST ELITE 4000 (VERTICAL)

Release Date: December 10, 2010
Publication Number: 620048956INS
Revision Date: July 1, 2019
Revision: H

Visit the Cornelius web site at www.cornelius.com for all your Literature needs.

The products, technical information, and instructions contained in this manual are subject to change without notice. These instructions are not intended to cover all details or variations of the equipment, nor to provide for every possible contingency in the installation, operation or maintenance of this equipment. This manual assumes that the person(s) working on the equipment have been trained and are skilled in working with electrical, plumbing, pneumatic, and mechanical equipment. It is assumed that appropriate safety precautions are taken and that all local safety and construction requirements are being met, in addition to the information contained in this manual.

This Product is warranted only as provided in Cornelius' Commercial Warranty applicable to this Product and is subject to all of the restrictions and limitations contained in the Commercial Warranty.

Cornelius will not be responsible for any repair, replacement or other service required by or loss or damage resulting from any of the following occurrences, including but not limited to, (1) other than normal and proper use and normal service conditions with respect to the Product, (2) improper voltage, (3) inadequate wiring, (4) abuse, (5) accident, (6) alteration, (7) misuse, (8) neglect, (9) unauthorized repair or the failure to utilize suitably qualified and trained persons to perform service and/or repair of the Product, (10) improper cleaning, (11) failure to follow installation, operating, cleaning or maintenance instructions, (12) use of "non-authorized" parts (i.e., parts that are not 100% compatible with the Product) which use voids the entire warranty, (13) Product parts in contact with water or the product dispensed which are adversely impacted by changes in liquid scale or chemical composition.

Contact Information:

To inquire about current revisions of this and other documentation or for assistance with any Cornelius product contact:

www.cornelius.com

800-238-3600

Trademarks and Copyrights:

This document contains proprietary information and it may not be reproduced in any way without permission from Cornelius.

This document contains the original instructions for the unit described.

CORNELIUS INC
101 Regency Drive
Glendale Heights, IL
Tel: + 1 800-238-3600

Printed in U.S.A.

TABLE OF CONTENTS

SAFETY INSTRUCTIONS	1
Read And Follow All Safety Instructions	1
Safety Overview	1
Recognition	1
Different Types of Alerts	1
Safety Tips	1
Qualified Service Personnel	2
Safety Precautions	2
Shipping And Storage	2
Mounting In or On A Counter	2
UNIT DIMENSIONS	3
Receiving	4
Unpacking	4
Nameplate Data	4
Concentrate Storage	4
Ice Bank/Pull Down	4
Applications	5
REQUIREMENTS	5
Counter Location	5
Minimum Airflow Clearance	5
Connecting the Water Supply	6
Plumbing and Water Supply Requirements	6
FILLING THE ICE BATH	7
Electrical Requirements	8
PRIMING/FLUSHING WATER SYSTEM	8
CONCENTRATE HANDLING AND LOADING	9
Loading Concentrate	9
Changing Concentrate Containers	9
BRIXING PROCEDURE	11
Supplies	11
Checking/Adjusting the BRIX Setting	11
Programming the Portion Control	12
Stop Button	12
PLANNED MAINTENANCE SCHEDULE	13
Daily	13
Flush System	13
Clean Splash Zones & Dispense Nozzles	13
Weekly	14
Sanitize the Juice Dispenser	14
Sanitize Pump System	14
Prepare Dispenser for Use	15
Semi Annually	15
Clean Water Inlet Strainer	15
Clean Chassis Interior	15
Check and Top-Off Water Ice Bath	16

Annually	16
Replace Pump Tubing and Clean Cabinet	16
Removing Pump Platform(s)	16
Replacing the Tubing	17
Cleaning the Cabinet	18
TROUBLESHOOTING GUIDE	19
ASSEMBLY DRAWINGS	22
CORNELIUS STANDARD SERVICE CALL GUIDE	24

SAFETY INSTRUCTIONS

READ AND FOLLOW ALL SAFETY INSTRUCTIONS

Safety Overview

- Read and follow **ALL SAFETY INSTRUCTIONS** in this manual and any warning/caution labels on the unit (decals, labels or laminated cards).
- Read and understand ALL applicable OSHA (Occupational Safety and Health Administration) safety regulations before operating this unit.

Recognition

<i>Recognize Safety Alerts</i>
 <p><i>This is the safety alert symbol. When you see it in this manual or on the unit, be alert to the potential of personal injury or damage to the unit.</i></p>

Different Types of Alerts

DANGER:

Indicates an immediate hazardous situation which if not avoided **WILL** result in serious injury, death or equipment damage.

WARNING:

Indicates a potentially hazardous situation which, if not avoided, **COULD** result in serious injury, death, or equipment damage.

CAUTION:

Indicates a potentially hazardous situation which, if not avoided, **MAY** result in minor or moderate injury or equipment damage.

SAFETY TIPS

- Carefully read and follow all safety messages in this manual and safety signs on the unit.
- Keep safety signs in good condition and replace missing or damaged items.
- Learn how to operate the unit and how to use the controls properly.
- **Do not** let anyone operate the unit without proper training. This appliance is **not** intended for use by very young children or infirm persons without supervision. Young children should be supervised to ensure that they do not play with the appliance.
- Keep your unit in proper working condition and do not allow unauthorized modifications to the unit.

NOTE: The dispenser is not designed for a wash-down environment and MUST NOT be placed in an area where a water jet could be used.

QUALIFIED SERVICE PERSONNEL

⚠ WARNING:

Only trained and certified electrical, plumbing and refrigeration technicians should service this unit.

ALL WIRING AND PLUMBING MUST CONFORM TO NATIONAL AND LOCAL CODES. FAILURE TO COMPLY COULD RESULT IN SERIOUS INJURY, DEATH OR EQUIPMENT DAMAGE.

IF THE SUPPLY CORD IS DAMAGED, IT MUST BE REPLACED BY THE MANUFACTURER, ITS SERVICE AGENT OR SIMILARLY QUALIFIED PERSONS IN ORDER TO AVOID A HAZARD.

SAFETY PRECAUTIONS

This unit has been specifically designed to provide protection against personal injury. To ensure continued protection observe the following:

⚠ WARNING:

Disconnect power to the unit before servicing following all lock out/tag out procedures established by the user. Verify all of the power is off to the unit before any work is performed.

FAILURE TO DISCONNECT THE POWER COULD RESULT IN SERIOUS INJURY, DEATH OR EQUIPMENT DAMAGE.

⚠ CAUTION:

Always be sure to keep area around the unit clean and free of clutter. Failure to keep this area clean may result in injury or equipment damage.

DO NOT STORE EXPLOSIVE SUBSTANCES SUCH AS AEROSOL CANS WITH A FLAMMABLE PROPELLANT IN THIS APPLIANCE.

CHILDREN SHALL NOT PLAY WITH THE APPLIANCE.

CLEANING AND USER MAINTENANCE SHALL NOT BE MADE BY CHILDREN WITHOUT SUPERVISION.

SHIPPING AND STORAGE

⚠ CAUTION:

Before shipping, storing, or relocating the unit, the unit must be sanitized and all sanitizing solution must be drained from the system. A freezing ambient environment will cause residual sanitizing solution or water remaining inside the unit to freeze resulting in damage to internal components.

MOUNTING IN OR ON A COUNTER

⚠ WARNING:

When installing the unit in or on a counter top, the counter must be able to support a weight in excess of 140 lbs. (63.5 kg.) to insure adequate support for the unit.

FAILURE TO COMPLY COULD RESULT IN SERIOUS INJURY, DEATH OR EQUIPMENT DAMAGE.

THE APPLIANCE HAS TO BE PLACED IN A HORIZONTAL POSITION

UNIT DIMENSIONS

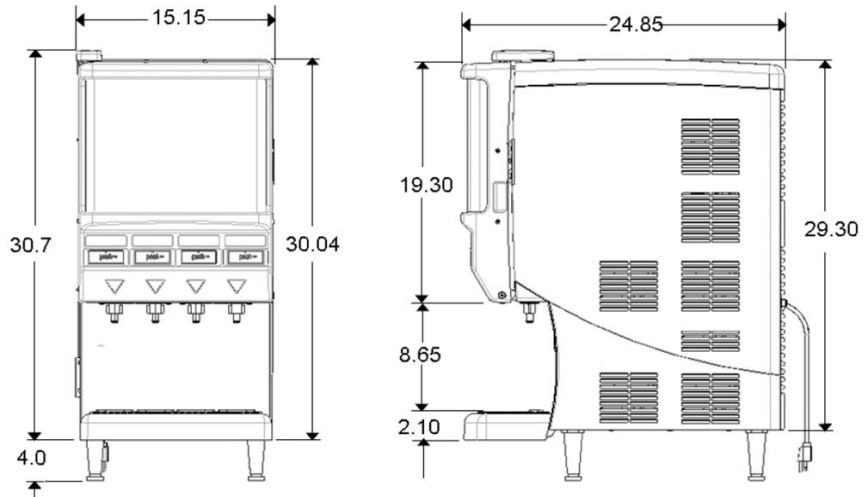

Figure 1. Quest Elite 4000

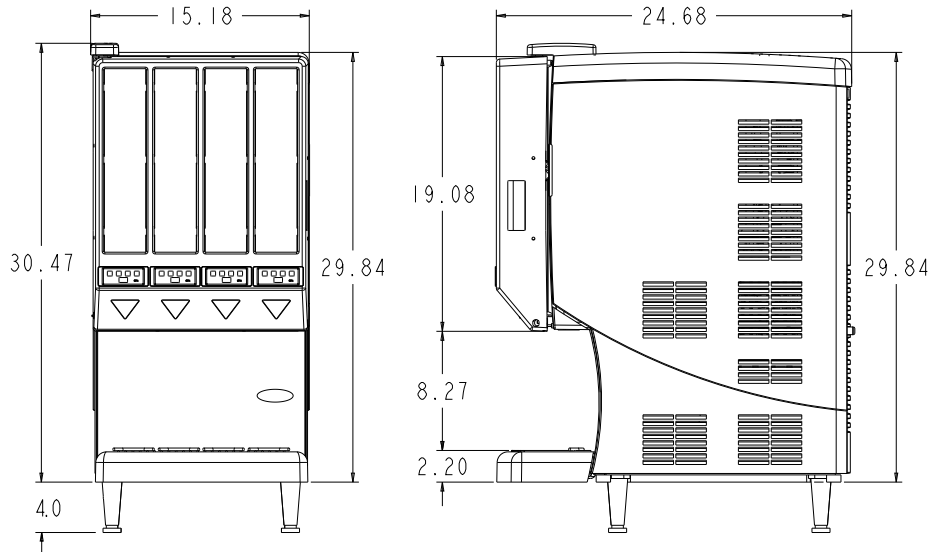

Figure 2 Quest Elite 4000 (Vertical)

RECEIVING

Each unit is completely tested and inspected before shipment. At the time of shipment, the carrier accepts the unit and any claim for damage must be made with the carrier.

Upon receiving the unit(s) from the carrier, inspect the carton for visible damage. If damage exists, have the carrier make a note on the bill of lading and file a claim with the carrier.

UNPACKING

- Remove staples securing carton to pallet.
- Lift carton up and off of unit.
- Remove inserts and shipping bag.
- Open upper cabinet door and remove installation kit.
- Remove bolts securing unit to pallet.
- Lift unit off of pallet.

NOTE: Do not lay the unit on it's side or back. This may cause vital oils to drain from the compressor resulting in damage during start-up and consequently voiding the warranty.

Nameplate Data

Models	VAC	Amps	Ph	Hz	Refrigerant			Test Pressure psi (Kpa) (bar)	
					Oz	Grams	Type	High side	Low side
QST Elite 4000	115	5	1	60	6.34-6.41	180-182	R-134a	400 (2757.9) / 27.6	88 (606.7) (6.1)
QST Elite 4000	230	2	1	50	6.34-6.41	180-182	R-134a	400 (2757.9) / 27.6	88 (606.7) (6.1)
QST Elite 4000	220	2	1	60	6.34-6.41	180-182	R-134a	400 (2757.9) / 27.6	88 (606.7) (6.1)
QST Elite 4000 (Vertical)	115	5	1	60	6.34-6.41	180-182	R-134a	400 (2757.9) / 27.6	88 (606.7) (6.1)

Concentrate Storage

Four 0.8 gallon (3.0 liter) disposable bottles.

NOTE: Refillable Concentrate reservoirs also available.



Figure 3. Concentrate Storage

Ice Bank/Pull Down

Weight 14-16 lbs. (6.35 - 7.25 kg.). Pull Down: 3.5 - 5.5 hours at 75°F (24°C)

APPLICATIONS

This appliance is intended to be used in household and similar applications such as the following:

- Staff kitchen areas in shops, offices and other working environments.
- Farm houses and by clients in hotels, motels and other residential type environments.
- Bed and breakfast type environments.
- Catering and similar non-retail applications.

REQUIREMENTS

Counter Location

Select a location in a well ventilated area, close to a grounded electrical outlet. If possible do not place the unit close to hot and/or steaming machines.

Minimum Airflow Clearance

The minimum airflow clearance is: 4" (10.16 cm) in back, 12" (30.48 cm) on top, 4" (10.16) at sides and open to the front.



IMPORTANT:

Condenser air is drawn in from the bottom of the rear panel and discharged out the top of the rear panel & side panels. Failure to maintain clearance space will reduce capacity of the unit and cause premature compressor failure.

The Dispenser needs to be placed using 4" legs that are included.

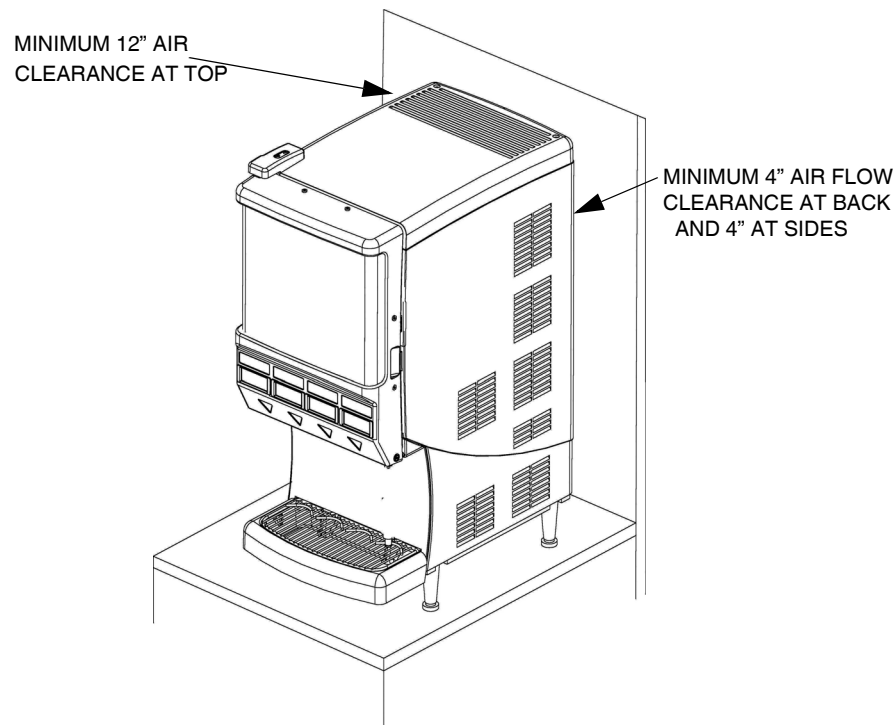

Figure 4. Minimum Clearances

CONNECTING THE WATER SUPPLY

The Quest Elite series Juice Dispenser is designed to dispense juice at a high flow rate. It is very important that the incoming water line be dedicated for use by the dispenser only and does not have other machines connected which could cause a water surge, (i.e., a dishwasher, coffee maker, etc.).

⚠ IMPORTANT:

The water supply should be consistent with proper water quality standards (neutral pH of 7.0 to 8.0), and should not be connected to a water softener. It is the installer's responsibility to ensure that all water connections to the dispenser are sized, installed with adequate backflow protection and maintained to comply with Federal, State, and Local Laws.

PLUMBING AND WATER SUPPLY REQUIREMENTS

This dispenser must be connected to a **COLD WATER** system with operating pressure between 30 psi (206.8 kPa) (2.1 bar) minimum (dynamic) and 60 psi (413.7 kPa) (4.1 bar) maximum (static). This water source must be capable of producing a minimum flow rate of 3 fluid ounces (88.7 ml) per second. A shut off valve should be installed in the line before the dispenser. Install a regulator in the line when pressure is greater than 60 psi (413.7 kPa) to reduce it to 50 psi (345 kPa) (3.5 bar) (dynamic). The regulator is also necessary if the water source has pressure fluctuations.

⚠ WARNING:

This equipment must be installed to comply with the International Plumbing Code of the International Code Council and the Food Code Manual of the Food and Drug Administration (FDA). For models installed outside the U.S.A., you must comply with the applicable Plumbing/Sanitation Code for your area.

Failure to comply could result in serious injury, death or damage to the equipment.

1. Secure the 3/8" (0.95 cm) swivel nut on the flexible supply tubing to the water inlet located at the rear of the dispenser. Make sure that the flared gasket is used (flared gasket P/N 311304000 is included with the installation kit).

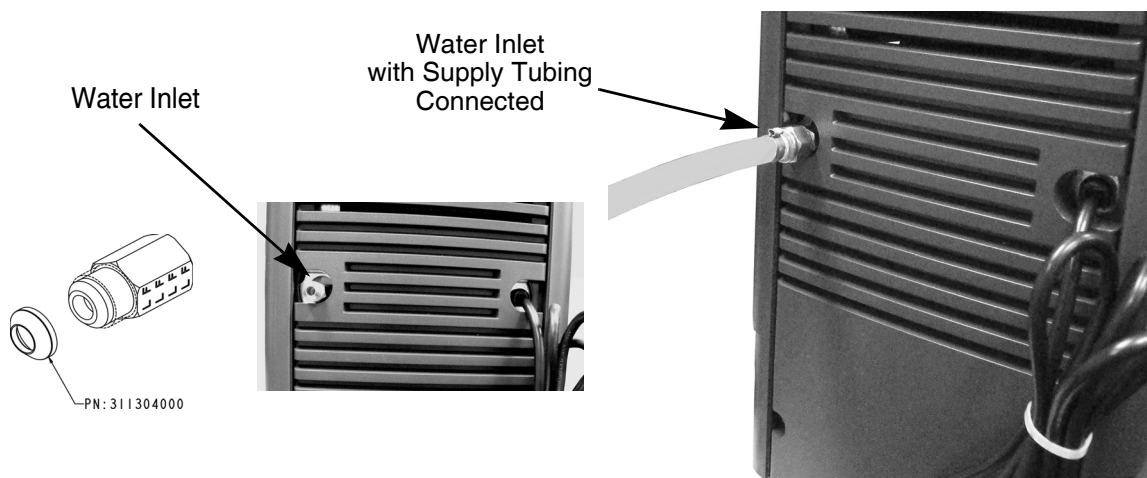

Figure 5. Water Supply Connection On Rear Of Unit

2. When securing flare nut, use a backup wrench on the male side of the inlet fitting (unit side) to prevent twisting of the copper tube inside the unit and/or possible damage to the water strainer/solenoid. Water shut off outside the unit is recommended.

FILLING THE ICE BATH

The ice bath holds approximately 3.5 gallons (13.4 liters) of water. The fill tube is located behind the front splash plate and capped with a 0.5" plug.

1. Remove the 0.5" plug and attach the tube to any one of the dispense nozzles.
2. Open the door and verify that the flush/dispense lever is in the dispense mode. (see Figure 6) Ice bath must always be filled in the dispense mode.

NOTE: Non flush units does not have a flush/dispense lever hence for filling water bath on non flush units please remove the concentrate Storage bottles first and then attach the tube to any one of the dispense nozzles and close the door, press and hold the dispense button (push) until the tank is filled and water trickles from the overflow

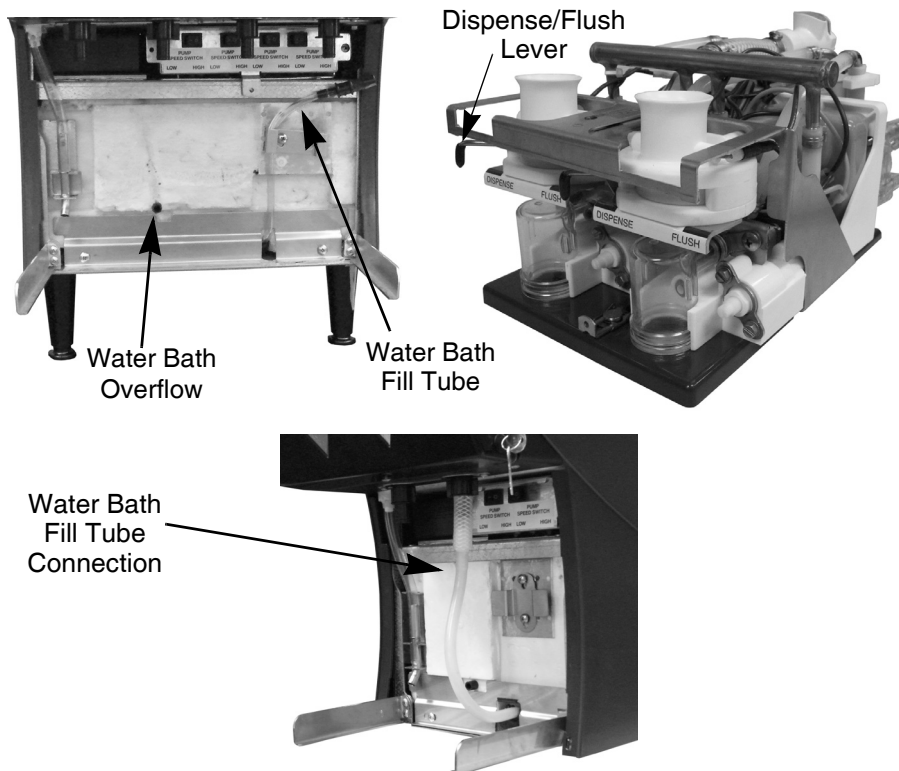

Figure 6. Water Bath and Dispense/Flush Lever

3. Close the door, press and hold the dispense button (push), shown in . Dispense Buttons, until the tank is filled and water trickles from the overflow.



Figure 7. Dispense Buttons

4. Once the ice bath is full, store the fill tube in the vertically recessed holder. The fill tube can now be used as a "sight glass" to monitor the water level in the ice bath.

ELECTRICAL REQUIREMENTS

⚠ CAUTION:

Only trained and certified electrical technicians should replace the power cord or the unit should be returned to an Authorized Service Center for power cord replacement." The replacement cord must meet all requirements of the original equipment manufacturer.

FAILURE TO COMPLY COULD RESULT IN SERIOUS INJURY, DEATH OR DAMAGE TO THE EQUIPMENT.

1. A minimum of 15 amps electrical service is needed for 120VAC power supply. A minimum of 10 amps electrical service is needed for 230VAC power supply.
2. 6 ft. long (1.83 m) power cord with 3-prong plug attached to dispenser. Export models are shipped with a European plug.

PRIMING/FLUSHING WATER SYSTEM

To properly prime the unit with water and remove air pockets in the system, open the cabinet door and make sure that all the valve levers are in the **Dispense** position.

Close the door and press the dispense button for a few seconds. Repeat until a steady flow of water is observed from all dispense valves.

NOTE: Some splashing may occur during this purge cycle.

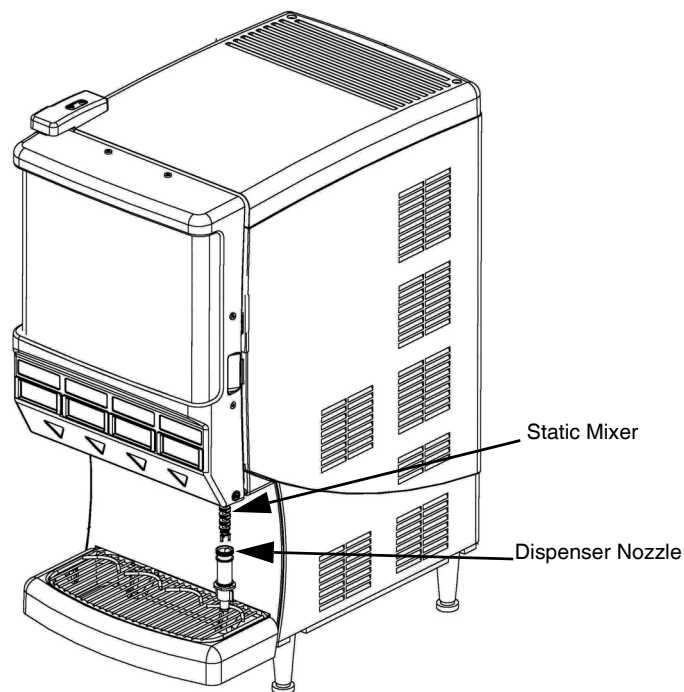

Figure 8. Dispense Nozzle

CONCENTRATE HANDLING AND LOADING

It is recommended that the concentrate be thawed in a refrigerated 35°F to 40°F (1.6°C to 4.4°C) compartment for a minimum of 48 hours prior to loading it into the Quest Juice Dispenser.

⚠ WARNING:

Concentrate must be completely thawed and within the temperature range of 35°F to 40°F (1.6°C to 4.4°C) prior to loading. Failing to supply concentrate inside the recommended temperature range, especially below 35°F (1.6°C), causes an out of BRIX drink (refer to the BRIXING Procedure section for details).

LOADING CONCENTRATE

The Quest Juice Dispenser is designed to use either disposable juice concentrate containers or the optional Cornelius generic refillable container (sold separately).



Figure 9. Refillable Concentrate Container

1. Thoroughly shake concentrate container prior to use.
2. Place concentrate containers on the dispensing platform shelf inside the refrigerated cabinet.
3. Engage the concentrate container by pressing it downward into the bottle adapter opening on the dispensing platform.

NOTE: Be sure to lubricate the o-ring seal on the container nozzle. This ensures a good seal and allows the pumps to draw concentrate from the containers more easily. Failure to create a good seal at this connection may result in weak drinks and/or seepage of concentrate.

4. Prime each pump by closing the cabinet door and press each dispense button until concentrate flows from the dispense nozzles.

CHANGING CONCENTRATE CONTAINERS

1. Open the cabinet door and move the valve handle from the *Dispense* to *Flush* position, see Figure 10.

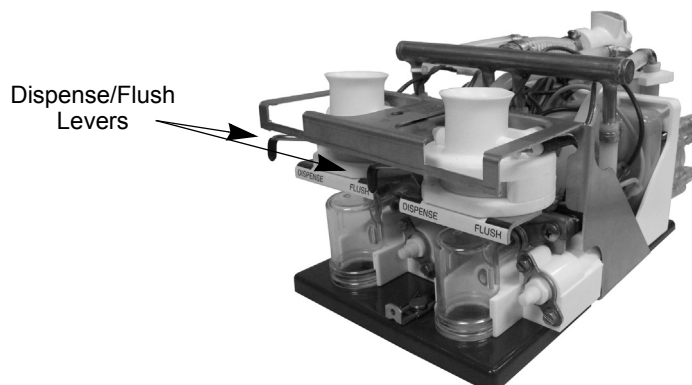

Figure 10. Dispense/Flush Lever Location

2. Close the door. Depress and hold the dispense button (Figure 11) until clear water flows from the dispense nozzle.

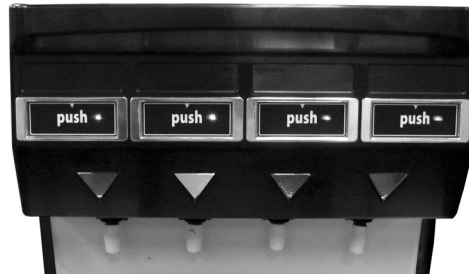

Figure 11. Dispense Buttons

3. Open the cabinet door and return the handle to the *Dispense* position.
4. Depress and hold the dispense button for 1-2 seconds. This relieves water pressure from the concentrate pump system.
 1. Load the concentrate container (see Figure 12)



Figure 12. Loading a Concentrate Container

BRIXING PROCEDURE

NOTE: If concentrate is not properly thawed, it will adversely affect the amount of concentrate dispensed. Thawed product should be between 35°F/1.6°C to 40°F/4.4°C.

SUPPLIES

- 1 - Small 12 oz. cup (354.8 ml)
- 1 - Large 21 oz. cup (621.1 ml)
- 1 - Straw
- Paper Towels
- 1 - Thermometer
- 1 - Refractometer
- 1 - Flat Bladed Screwdriver

NOTE: Refractometer P/N 511004000 is available through your local Cornelius Distributor.

CHECKING/ADJUSTING THE BRIX SETTING

The following instructions are for use with a refractometer.

1. Dispense approximately 8 oz. (237 ml) of drink and discard. Now draw a second 8 oz. (237 ml) drink.
2. Check drink temperature with a accurate thermometer (target is 35 to 45°F, or 1.6 to 7.2°C). Discard this drink after checking temperature.

NOTE: If drink temperature is not within the target range, refer to the basic troubleshooting section.

3. Dispense a 12 oz (354.8 ml) drink sample into a clean, 21 oz (621.ml) dry cup. Thoroughly stir the sample using a straw.
4. Using the straw, transfer a small sample of the finished drink to the refractometer lens (refer to operating instructions supplied with your refractometer). Check the BRIX reading against the BRIX chart shown in Table 2.

NOTE: The BRIX chart shown in Table 2 is generic and intended for reference use only. Contact your frozen concentrate supplier for specific BRX readings.

Table 1.

Flavor	Ratio	BRIX
Orange Juice	4+1	11.8
Grapefruit Juice	5+1	10.6
Cranberry Cocktail	4+1	13.5
Apple Juice	5+1	12.0
Grape	5+1	13.0
Lemonade	5+1	10.5
Tropical Punch	5+1	11.8
Sweetened Ice Tea	7+1	6.0
Pineapple Juice	4+1	12.8
Prune Juice	2+1	16.0

5. To change the BRIX setting, simply re-adjust the water flow rate. Located on each of the valve assemblies inside the refrigerated compartment are the adjusting screws for the water flow rate (one per valve).

If the BRIX reading is too high or low, rotate the appropriate water flow control according to Figure 13. Repeat steps

1-5 until the proper BRIX setting is achieved.

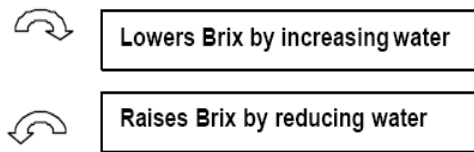

Water Flow Controls

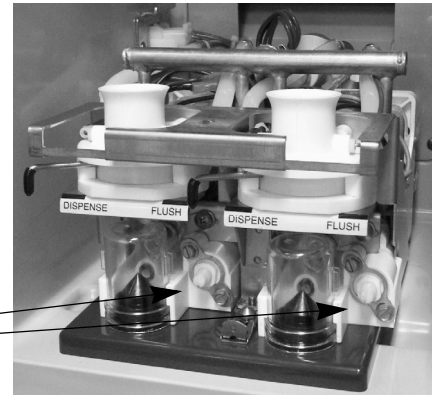

Figure 13.

IMPORTANT: When making changes to the water flow control, do not rotate more than 1/4 turn per adjustment. Additionally, prior to taking your next BRIX reading, momentarily press the corresponding dispense button several times prior to drawing a sample. This clears any remnants from the dispense nozzle and helps move the flow control to its new setting.

PROGRAMMING THE PORTION CONTROL

If the dispenser has optional portion controls, they have been pre-programmed from the factory to pour 7, 12, and 16 ounce drinks. The “extra large” (pitcher icon) size has also been pre-programmed to pour 16 ounces.

To change the pour sizes, please perform the procedure described in .

Table 2.

Step	Action
1	Simultaneously, press and hold Small and Extra Large buttons on the Portion Control Module until the Refill light starts blinking. Release the buttons. The blinking Refill light indicates the programming mode is active. See . Control Panel.
2	Place a cup under the dispense nozzle and push the selected size button (small, medium, large, or extra large). Hold the button in until the cup fills to the desired portion, then release the button. Repeat the procedure for the remaining sizes.
3	After programming all the drink sizes, press and release the Stop button to return the Portion Control to the operational mode. The blinking REFILL light goes off.
4	In the future, to change the portion size of the drinks, the individual sizes can be adjusted by performing Step 2. It is not necessary to reprogram every size. Additionally, the portion control has full memory retention in case of a power failure.

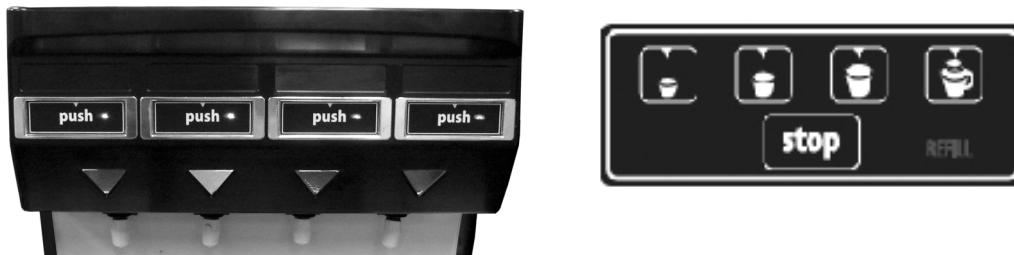

Figure 14. Control Panel

STOP BUTTON

To pour a drink without using a pre-programmed portion control size, simply push and hold the Stop button. Release when the glass is full.

PLANNED MAINTENANCE SCHEDULE

DAILY

Flush System

1. Move all of the Dispense/Flush levers (located on the platform assembly in the refrigerated cabinet) to the *Flush* position. Place an empty cup on the drip tray below each dispense nozzle (Figure 15).

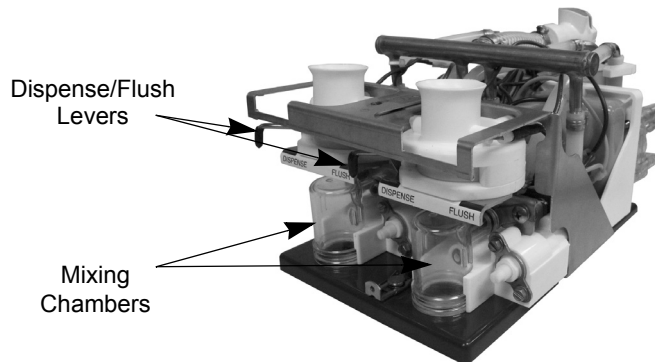

Figure 15. Platform Assembly with Dispense/Flush Levers

2. Close the door and depress each dispense button for 2-3 seconds or until clear water flows from each dispense nozzle.



Figure 16. Dispense Buttons

3. Return the Dispense/Flush levers to the *Dispense* position.
4. Press each Dispense button for 1 to 2 seconds to release the water pressure present in the concentrate pump system.

Clean Splash Zones & Dispense Nozzles

1. On a daily basis, using a clean, damp cloth, clean the external cabinet and splash areas including the door gasket. Remove and wash the cup rest and drip tray using mild dish soap.
2. Remove the dispense nozzles and static mixers by rotating each 90° and pulling down. Remove the mixing chambers by pulling straight forward. Wash using mild dish soap.

IMPORTANT: DO NOT wash nozzles, static mixers, or mixing chambers in a dish washer. This will distort the plastic and damage the o-rings. Additionally, do not soak them in sanitizing solution longer than 2 minutes.

Flush once a day for better quality drinks.

WARNING:

Do not leave the unit in FLUSH mode. Leaving the unit in flush mode may result in damage.

WEEKLY

Check concentrate to water brix ratio (refer to the Checking/Adjusting the See “BRIXING Procedure” on page 11.).

Sanitize the Juice Dispenser

1. Rinse the unit with hot water.
2. Prepare two 2 oz. (59 ml) packets of Stera-Sheen Green Label sanitizing solution (or similar brand) by dissolving each packet in 1 gallon (3.8L) of potable water to insure 200 ppm of available chlorine.

IMPORTANT: Use potable water at 80°F-100°F (26.7°C-37.8°C). Water above this range breaks down the chlorine count and minimizes sanitation.
3. Remove the juice concentrate containers and place them in separate refrigerated compartment.
4. Flush the system by following the instructions in See “Flush System” on page 13..
5. Fill a clean empty concentrate container with one quart of extremely hot tap water, approximately 140°F (60°C) and place the container into the unit. Dispense all of the hot water into a large container. Repeat for all the remaining dispense valves.
6. Remove the mixing chambers, nozzles, and static mixers. Rinse in hot water to remove excess pulp and concentrate.
7. Place the mixing chambers, nozzles, and static mixers in a separate container of sanitizing solution and agitate vigorously. Allow the parts to soak for two minutes, then rinse thoroughly with fresh tap water.
8. Reinstall the static mixer, nozzles, and mixing chambers

Sanitize Pump System

1. Fill a clean concentrate container with 2 quarts (1.9L) of fresh sanitizing solution.
2. Place Dispense/Flush levers (located on the platform assembly in the refrigerated cabinet) to the *Dispense* position and close the door.

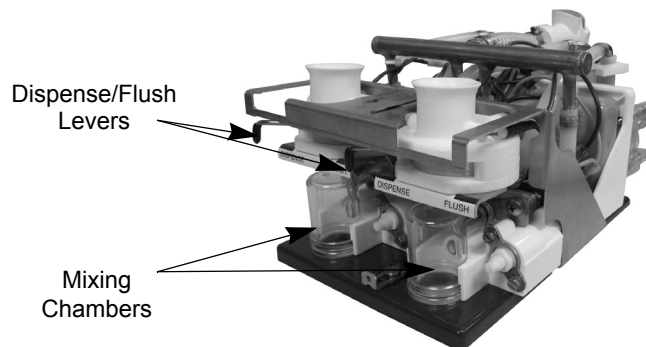

Figure 17. Dispense/Flush Levers

3. Press and hold the dispense button for 90 seconds then release. Allow sanitizing solution to remain in the lines for 5 minutes.



Figure 18. Dispense Buttons

4. After 5 minutes, dispense the remaining sanitizing solution.

Prepare Dispenser for Use

1. Replace sanitizing solution container with a concentrate container and close the door.
2. Press and hold the dispense button until juice appears from the nozzle. Next dispense and discard at least two 8 oz. (236.6ML) cups of juice in order to prime the system and prepare it for operation.

SEMI ANNUALLY

CAUTION:

The following procedures require removal of the dispenser side panel(s). Disconnect the power cord (See Figure 19.) from the receptacle prior to proceeding.



Figure 19. Pull AC Plug from Wall Outlet

Clean Water Inlet Strainer

1. Remove the right side panel from the dispenser.
2. Turn off the water supply to the dispenser.
3. Remove the access port from the “Y” shaped water inlet solenoid located on the right side of the dispenser. (See Figure 20)
4. Clean and reinstall the stainless steel water strainer.



Figure 20. Right Side of Dispenser

Clean Chassis Interior

1. Clean the condenser cooling fins.
2. Clean the air inlet grilles located on the rear and top panels of the dispenser.
3. Clean the interior base.
4. Wipe the fan blades clean.
5. Reinstall the right side panel, turn on the water supply, and plug the dispenser into the power receptacle.

Check and Top-Off Water Ice Bath

1. Remove the drip tray and lower splash panel.



Figure 21. Drip Tray and Cup Rest

If the Ice bath level is below the **FULL** indicator, top it off with water. Refer page 7 for the ice bath procedure

ANNUALLY

Replace Pump Tubing and Clean Cabinet

A replacement pump tubing kit, part # 45098, is available. The kit consists of one pre-cut length of pump tubing, two white plastic hose clamps, and instructions.

Removing Pump Platform(s)

1. Remove the concentrate containers from the dispenser and place them in a refrigerator.
2. Remove the cabinet shelf that the concentrate containers sit on.
3. Flush the system prior to removing the pump platform (refer to the Daily). Remove the dispense nozzles and static mixers.
4. Unplug the water line quick disconnect by pressing the gray button (See Figure 22).

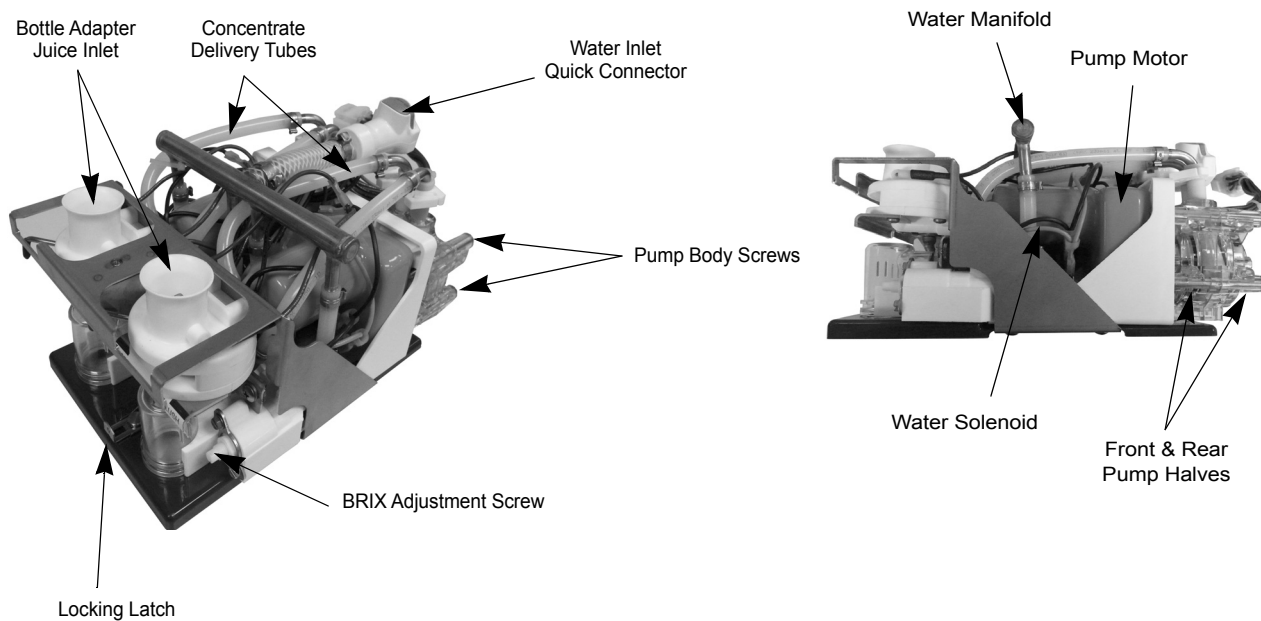

Figure 22. Interior Details

5. Slide the locking latch forward. Lift the platform slightly and pull forward to gain access to the electrical connector (see Figure 22).

- Unplug the electrical connector by squeezing the locking tabs on either side and pulling out the connector. Lift and remove the pump platform (see Figure 22).

Replacing the Tubing

When the pump platform has been removed, replace the tubing by performing the following procedure.

- Remove the two white plastic hose clamps from the pump tube connections (See Figure 22) and remove the concentrate delivery tubes from the hose ends.
- Loosen and remove the four screws from the pump body (See Figure 23).

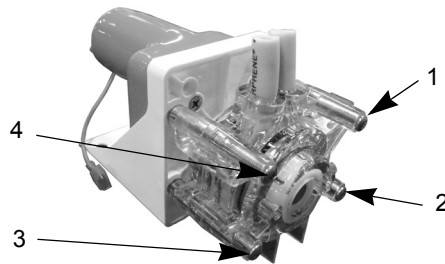

Figure 23. Pump Body Screws

- Remove **ONLY** the rear pump body half to reveal the pump tubing and rollers (See Figure 24).
- Remove the old pump tubing from the pump body. If the roller assembly comes out with the tubing, place it back into the pump housing. **Make sure to align the roller assembly shaft key way to the motor shaft so that the two interlock.**
- Firmly press the new tubing into the pump body around the roller assembly, making sure to keep the protruding ends even with each other.
- Once the tubing is in place, hold the tubing with one hand, capture the lower part of the tubing with the outer housing, then proceed to capture the shaft of the roller assembly and push the rear pump housing into place. Make sure to capture the tubing within the body and not pinch it between the halves. Do not use any tool other than your finger tips to manipulate the tubing into the housing or you may damage the tubing.

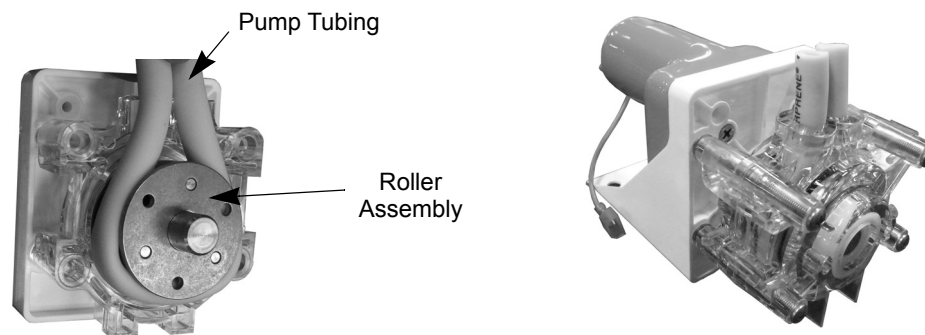

Figure 24. Pump Assembly

- While holding the pump halves together with your hand, reinsert the four thumb screws (See Figure 23) and tighten using a criss-cross pattern as shown. The thumb screws should be tightened about 1/4 turn beyond snug.
- Insert the two concentrate delivery tubes into the pump tubing ends and secure them using the new hose clamps supplied in the kit. Be sure to use pliers to squeeze and tighten the hose clamps.

Cleaning the Cabinet

The cabinet bottom surface and walls should be inspected and cleaned annually according to the following steps:

1. Remove natural rubber nozzle bushing gasket (see Figure 25) and inspect it and silicone RTV. If cracked, clean off RTV, and re-apply using kit P/N 729011013 per instructions provided with kit.
2. Re-apply nozzle bushing gasket so that the edges lie flat on the floor of the cabinet.

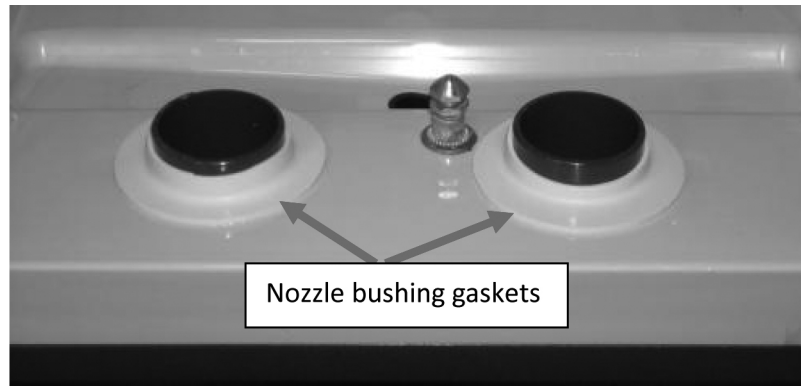

Figure 25. Nozzle bushing gaskets - proper installation

3. Clean cabinet floor and walls of any spilled juice and let dry. Use a mild soap/detergent and plain water.
4. Reinstall the pump platform in the reverse order given above.

TROUBLESHOOTING GUIDE

The following tables contain trouble-shooting information intended to aid an experienced service person in diagnosing operational problems that may occur. For further assistance, contact the Cornelius Customer Services department at 800-283-3600 between the hours of 7:30A.M. and 5:00P.M. Central Standard Time. You must have the model and serial number (Located on the right side of the dispenser) when calling.

Table 3

Symptom	Probable Cause	Remedy
Unit totally inoperative	<ul style="list-style-type: none"> A. No power to dispenser due to tripped circuit breaker. B. Loose or broken power supply connection inside dispenser. 	<ul style="list-style-type: none"> A. Reset circuit breaker. Confirm that breaker is correct size & no other equipment is operating on the same circuit. Also confirm that supply voltage is +/-10% of nameplate specification. B. Repair connection.
No Cooling	<ul style="list-style-type: none"> A. Line voltage not within nameplate specification causing compressor overload to trip. B. No water in water ice bath or water level extremely low, exposing ice bank sensing probe. C. Defective Ice Bank Control or sensing probe. D. Cabinet fan inoperative resulting in warm concentrate (water continues to cool). E. Compressor short cycles on overload. F. Compressor starts but hums & trips overload. G. Defective compressor overload or start capacitor. H. Compressor starts but does not switch off of start winding. I. Refrigerant leak. 	<ul style="list-style-type: none"> A. Contact an electrician. B. Fill ice bath to proper water level. C. Replace. D. Replace. E. Excessively high discharge pressure due to restricted condenser or inoperative condenser fan motor. F. Seized or shorted compressor, replace. G. Test & replace. H. Relay or compressor is defective. Test & replace faulty item. I. Repair leak, evacuate & recharge system.
No water dispensed, concentrate only	<ul style="list-style-type: none"> A. No water in dispenser. B. Water supply line inside refrigerated cabinet disconnected from pump platform. C. Water solenoid located on pump platform clogged or defective. D. Main water solenoid/strainer located at the rear of dispenser is clogged, binding or defective. E. Water supply pressure is greater than 80 psi (5.5 bar) forcing BRIX flow control closed. F. Freeze-up of water coil in ice bath. 	<ul style="list-style-type: none"> A. Restore water. B. Reconnect C. Disassemble & clean solenoid. Replace if necessary. D. Remove & clean strainer. Confirm 24VDC is present at solenoid during dispense. Confirm solenoid coil is not open. Disassemble & clean solenoid. E. Add external regulator & lower pressure to 50 psi (3.5 bar). F. Unplug dispenser & allow 2-4 hrs. to thaw. Check operation of agitator motor & ice bank control. Refrigeration system may be low on charge resulting in a deformed ice bank & freeze-up of water coil in ice bath.

Table 3

Symptom	Probable Cause	Remedy
No water & no concentrate, refrigeration is working.	<ul style="list-style-type: none"> A. Black service switch located on the rear of the cabinet door in OFF position. B. White door switch open C. 6.25 amp fuse inside front electrical box blown. D. No output from transformer. E. Defective voltage regulator board (VRB) located inside front electrical box. F. Defective dispense push button or portion control board. 	<ul style="list-style-type: none"> A. Turn on switch. B. Door switch must be closed in order to dispense. Check switch operation & replace if necessary. C. Replace with 6.25, 250VAC slow blow fuse & test. D. Confirm transformer output of 24VAC +/-2. Replace transformer if necessary. E. Measure across the VDC output of the board. There should be 28VDC present when the dispense button is pressed. Replace VRB if necessary. F. Test & replace if necessary.
No concentrate dispensed, water only.	<ul style="list-style-type: none"> A. Concentrate container not fully engaged into receptacle on pump platform. B. Dispense/Flush lever in FLUSH position C. Concentrate too cold, not properly thawed. D. Defective pump motor. 	<ul style="list-style-type: none"> A. Refer to Concentrate Loading section of this manual. B. Move lever to DISPENSE position C. Concentrate should be 35 to 40°F (1.7 to 4.5°C) prior to loading. D. Replace pump motor.
Warm drinks	<ul style="list-style-type: none"> A. Ambient air around dispenser is too warm. B. Excessive demand on dispenser. C. Dirty condenser coil. D. Inoperative condenser fan. E. Defective Ice Bank Control. F. Loss of refrigerant charge due to leak in system. 	<ul style="list-style-type: none"> A. Relocate dispenser. B. Add water pre-cooler or second dispenser C. Clean condenser coil. D. Replace condenser fan motor. E. Test & replace if necessary. F. Repair leak and recharge system.
Water continuously drips from nozzle in OFF mode.	<ul style="list-style-type: none"> A. Main water solenoid at base of unit or water solenoid on pump platform not shutting off completely. 	<ul style="list-style-type: none"> A. Clean solenoid(s), replace parts as necessary (refer to Planned Maintenance section).
Concentrate warm, water cold.	<ul style="list-style-type: none"> A. Cabinet fan inoperative. B. Agitator motor/pump inoperative or restricted. C. Loss of refrigerant charge due to leak in system. 	<ul style="list-style-type: none"> A. Check/replace fan. B. Check/replace agitator motor. C. Repair leak & recharge system.
BRIX problem	<ul style="list-style-type: none"> A. Water supply pressure too low, less than 20 psi (1.4 bar) flowing water pressure. B. Water flow control binding or spring is defective. C. Improperly thawed concentrate. BRIX changes as concentrate temperature changes (concentrate becomes thinner as temperature rises) 	<ul style="list-style-type: none"> A. Correct water supply problem to ensure a constant 50 psi (3.5 bar) flowing to dispenser. B. Clean and/or replace parts as necessary. C. Concentrate should be 35 to 40°F (1.7 to 4.5°C) prior to loading.

Table 3

Symptom	Probable Cause	Remedy
Pump inoperative	<p>A. Pump motor defective.</p> <p>B. No power to transformer or no 24VAC output from transformer.</p> <p>C. Defective voltage regulator board (VRB) located inside front electrical box.</p> <p>D. Defective dispense control board (Push button or portion control).</p>	<p>A. 28VDC should be present at pump motor during dispense. If voltage is present & motor does not start, replace motor.</p> <p>B. Confirm transformer has line voltage present on primary side. If no 24VAC output from secondary, replace transformer.</p> <p>C. Confirm board produces 28VDC present when dispense button is pressed (refer to Electrical Box Wiring Diagram for VDC output location). Replace VRB if necessary.</p> <p>D. Test & replace if necessary.</p>
Machine continues to dispense after dispense button is released or dispenses without operator input.	<p>A. Push button or portion control pad stuck in ON position.</p> <p>B. Relay on voltage regulator board (VRB) stuck on.</p>	<p>A. Disconnect wire harness from rear of portion control and close the door. If unit does not dispense on its own, dispense control board is bad (stuck on).</p> <p>B. Disconnect 4-wire harness from lower right corner of VRB. If unit continues to dispense on its own VRB is defective (relay stuck on).</p>

ASSEMBLY DRAWINGS

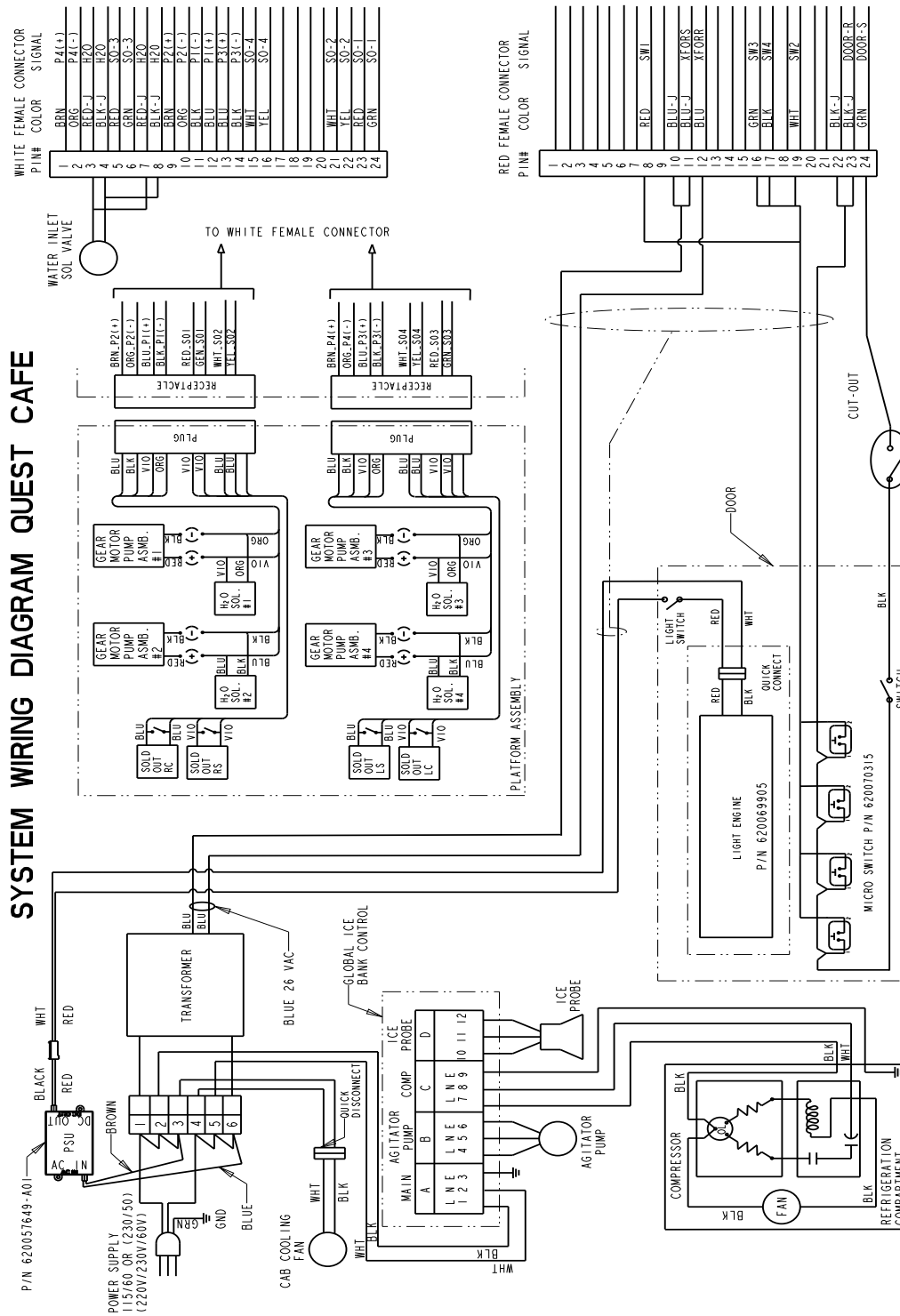
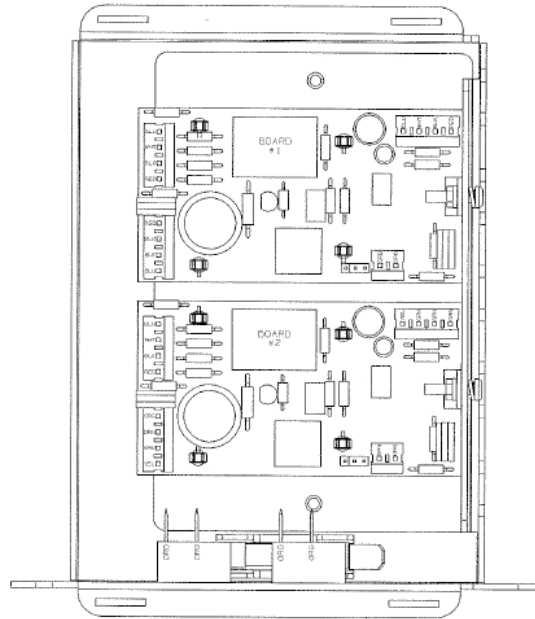

Figure 26. System Wiring Diagram Quest Elite 4 FL



ELECTRICAL BOX WIRING
WHITE TOP CONNECTOR

PIN#	CLR	SIG	BRD#
1	BRN	J1-4	4
2	ORG	J1-3	4
3	RED	J1-2	3,4
4	BLK	J1-1	3,4
5	RED	J3-2	3
6	GRN	J3-1	3
7	RED	J1-2	1,2
8	BLK	J1-1	1,2
9	BRN	J1-4	2
10	ORG	J1-3	2
11	BLK	J1-3	1
12	BLU	J1-4	1

PIN#	CLR	SIG	BRD#
13	BLU	J1-4	3
14	BLK	J1-3	3
15	WHT	J3-2	4
16	YEL	J3-1	4
17			
18			
19			
20			
21	WHT	J3-2	2
22	YEL	J3-1	2
23	RED	J3-2	1
24	GRN	J3-1	1

RED BOTTOM CONNECTOR

PIN#	CLR	SIG	BRD#
1			
2			
3			
4	GRY	J4-2	3
5	PUR	J4-3	3
6	GRN	J4-3	4
7	BRN	J4-3	2
8	BLU	J4-4	1
9	WHT	J4-2	1
10	BLU	J3-3	3,4
11	BLU	J3-3	1,2
12	BLU	FUSE-S	

PIN#	CLR	SIG	BRD#
13			
14			
15			
16	PNK	J4-4	3
17	ORG	J4-4	4
18	YEL	J4-2	4
19	TAN	J4-4	2
20	BLK	J4-2	2
21	RED	J4-3	1
22	WHT	J3-4	3,4
23	WHT	J3-4	1,2
24	BLU	FUSE-R	

Figure 27. Main Electrical Box Wiring Diagram Quest Elite 4 FL

Cornelius Inc.
www.cornelius.com