



# Post-Mix Valves UF-1™ and UFB-1™

CATG8683-0811

Specification Sheet



## Features

- Consistent performance and drink quality
- Variable flow rate satisfies demands for low and high flow valves
- Dispenses a great-tasting drink at optimum carbonation level
- Superior brix repeatability
- Aesthetically appealing flow is smooth and meets brix stratification specs
- Improved ratio control reduces service calls
- Simple-to-adjust screws reduce set-up time
- Sealed electronics enhance reliability
- Streamlined one-piece nozzle assembly
- Corrosion-free stainless steel valve lever
- Easy to install, clean and service
- Eye-catching brand merchandising
- Provides unsurpassed reliability
- Modular components provide consistent, reliable performance
- Components have been life tested to over 1 million cycles



Marmon Foodservice  
Technologies

A Berkshire Hathaway Company



# Post-Mix Valves

## UF-1™ and UFB-1™

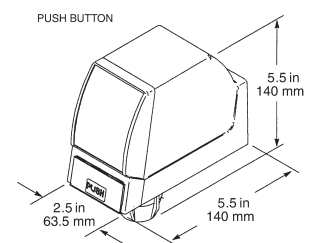
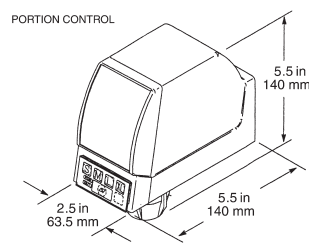
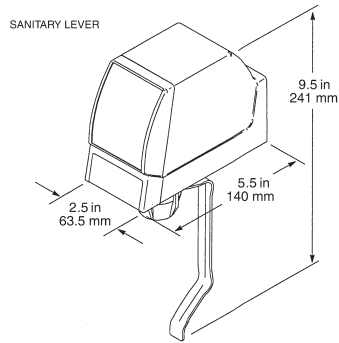
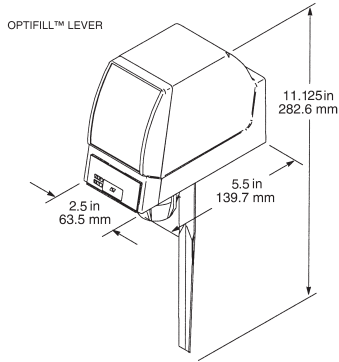

CATG8683-0811

### Specification Sheet



## Technical Specifications

<b>Operational Relative Humidity Range</b>	20-100%
<b>Operational Temperature Range</b>	32°-140°F (0°-60°C)
<b>Electrical Requirements</b>	24V/50Hz/60Hz

<b>Graphic Dimensions (If Applicable)</b>	Front: 2.91"H x 1.9"W (top) x 2" (bottom) Back: 1.22"H x 1.97" (top) x 2" (bottom)
<b>Agency Listed under model: 1965</b>	UL, NSF  

Part Number	Description	Flow
<b>Portion Control Valves</b>		
2307	UF-1™ ceramic regulator, with mounting block and covers	1.5-3oz (44.4-88.8mL)
561000159	UFB-1™ ceramic regulator, with mounting block and covers	2-4oz (60-120mL)
2312	UF-1™ ceramic regulator, without mounting block and covers	1.5-3oz (44.4-88.8mL)
561000158	UFB-1™ ceramic regulator, without mounting block and covers	2-4oz (60-120mL)
<b>Push Button Valves</b>		
2304	UF-1™ ceramic regulator, with mounting block and covers	1.5-3oz (44.4-88.8mL)
1966	UF-1™ ceramic regulator, without mounting block and covers	1.5-3oz (44.4-88.8mL)
561000162	UFB-1™ ceramic regulator, with mounting block and covers	2-4oz (60-120mL)
561000161	UFB-1™ ceramic regulator, without mounting block and covers	2-4oz (60-120mL)
<b>Optifill™ Automatic Shut-off Valves</b>		
2306	UF-1™ ceramic regulator, with mounting block and covers	1.5-3oz (44.4-88.8mL)
561000165	UFB-1™ ceramic regulator, with mounting block and covers	2-4oz (60-120mL)
561000164	UFB-1™ ceramic regulator, without mounting block and covers	2-4oz (60-120mL)
<b>Sanitary Lever Valves</b>		
561000121	UF-1™ ceramic regulator, with mounting block and covers	1.5-3oz (44.4-88.8mL)
561000120	UF-1™ ceramic regulator, without mounting block and covers	1.5-3oz (44.4-88.8mL)
561000156	UFB-1™ ceramic regulator, with mounting block and covers	2-4oz (60-120mL)
561000155	UFB-1™ ceramic regulator, without mounting block and covers	2-4oz (60-120mL)

Part Number	Description	Flow
<b>Juice Valves</b>		
561000126	Sanitary Lever Valve with mounting block and covers	1.5-3oz (44.4-88.8mL)
561000124	Sanitary Lever Valve without mounting block and covers	
561000102	Push Button activation without mounting block and covers	

To learn more about **Cornelius Post-mix Valves**, visit [cornelius.com](http://cornelius.com)