

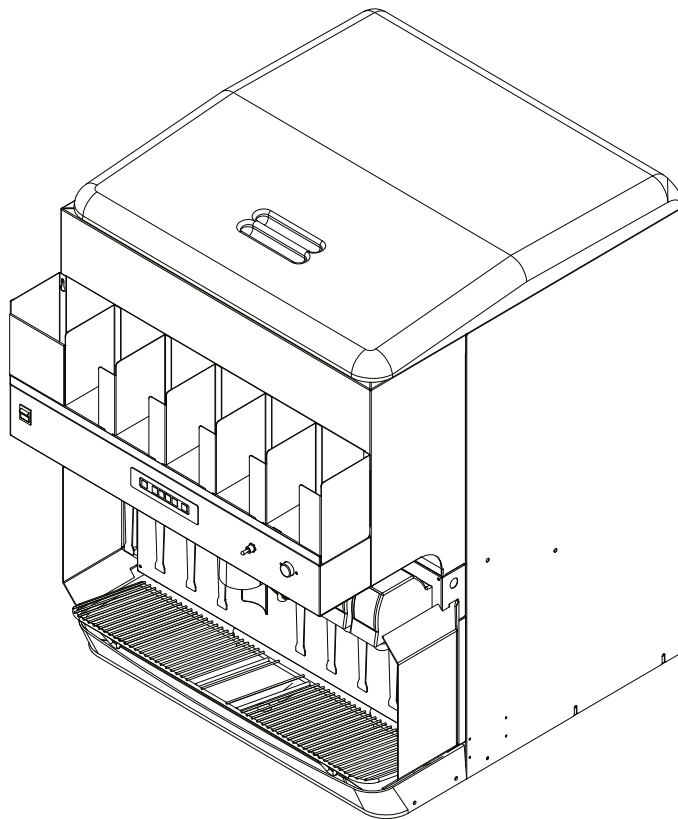

---

# ENDURO ICE/BEVERAGE DISPENSER Operator's Manual

Model: ED-250 BCP



Release Date: June 7, 1999

Publication Number: 620916502OPR

Revision Date: January 30, 2015

Revision: E

Visit the Cornelius web site at [www.cornelius.com](http://www.cornelius.com) for all your Literature needs.

---

The products, technical information, and instructions contained in this manual are subject to change without notice. These instructions are not intended to cover all details or variations of the equipment, nor to provide for every possible contingency in the installation, operation or maintenance of this equipment. This manual assumes that the person(s) working on the equipment have been trained and are skilled in working with electrical, plumbing, pneumatic, and mechanical equipment. It is assumed that appropriate safety precautions are taken and that all local safety and construction requirements are being met, in addition to the information contained in this manual.

This Product is warranted only as provided in Cornelius' Commercial Warranty applicable to this Product and is subject to all of the restrictions and limitations contained in the Commercial Warranty.

Cornelius will not be responsible for any repair, replacement or other service required by or loss or damage resulting from any of the following occurrences, including but not limited to, (1) other than normal and proper use and normal service conditions with respect to the Product, (2) improper voltage, (3) inadequate wiring, (4) abuse, (5) accident, (6) alteration, (7) misuse, (8) neglect, (9) unauthorized repair or the failure to utilize suitably qualified and trained persons to perform service and/or repair of the Product, (10) improper cleaning, (11) failure to follow installation, operating, cleaning or maintenance instructions, (12) use of "non-authorized" parts (i.e., parts that are not 100% compatible with the Product) which use voids the entire warranty, (13) Product parts in contact with water or the product dispensed which are adversely impacted by changes in liquid scale or chemical composition.

### **Contact Information:**

To inquire about current revisions of this and other documentation or for assistance with any Cornelius product contact:

**[www.cornelius.com](http://www.cornelius.com)  
800-238-3600**

### **Trademarks and Copyrights:**

This document contains proprietary information and it may not be reproduced in any way without permission from Cornelius.

This document contains the original instructions for the unit described.

**CORNELIUS INC**  
101 Regency Drive  
Glendale Heights, IL  
Tel: + 1 800-238-3600

Printed in U.S.A.



# TABLE OF CONTENTS

<b>Safety Instructions</b> .....	<b>1</b>
Read and Follow ALL Safety Instructions .....	1
Safety Overview .....	1
Recognition .....	1
Different Types of Alerts .....	1
Safety Tips .....	1
Qualified Service Personnel .....	1
Safety Precautions .....	2
Shipping And Storage .....	2
CO2 (Carbon Dioxide) Warning .....	2
Mounting in or on a Counter .....	2
<b>Start-up and Operating Instructions</b> .....	<b>4</b>
Ice Drink Dispenser .....	4
Controls and Electrical .....	5
Portion Control Panel .....	5
Portion Control Panel Operations .....	6
Ice Portion Control Set Up and Adjustment Procedure .....	6
<b>Cleaning and Maintenance Instructions</b> .....	<b>8</b>
Daily Cleaning: .....	8
Daily Maintenance: .....	8
Weekly Cleaning: (In addition to daily procedures) .....	8
Monthly Cleaning: (In addition to daily and weekly procedures) .....	9
Yearly Maintenance: .....	9
Cleaning Interior Surfaces (Monthly Cleaning) .....	9
Cold Plate (Yearly Maintenance) .....	9
Dispensing Valves: ( Daily Cleaning) .....	10
Product Tubing (Monthly Cleaning) .....	10
Sanitize Pre-Mix And Post-Mix Tank System .....	10
Sanitize syrup lines, BIB Systems .....	10
Replenishing CO2 Supply (As Required): .....	11
<b>Troubleshooting</b> .....	<b>12</b>
Trouble .....	12
Probable Cause .....	12
Remedy .....	12



# SAFETY INSTRUCTIONS

## READ AND FOLLOW ALL SAFETY INSTRUCTIONS

### Safety Overview

- Read and follow **ALL SAFETY INSTRUCTIONS** in this manual and any warning/caution labels on the unit (decals, labels or laminated cards).
- Read and understand ALL applicable OSHA (Occupational Safety and Health Administration) safety regulations before operating this unit.

### Recognition

#### *Recognize Safety Alerts*



*This is the safety alert symbol. When you see it in this manual or on the unit, be alert to the potential of personal injury or damage to the unit.*

## DIFFERENT TYPES OF ALERTS

### **DANGER:**

Indicates an immediate hazardous situation, which if not avoided, **WILL** result in serious injury, death or equipment damage.

### **WARNING:**

Indicates a potentially hazardous situation, which if not avoided, **COULD** result in serious injury, death, or equipment damage.

### **CAUTION:**

Indicates a potentially hazardous situation, which if not avoided, **MAY** result in minor or moderate injury or equipment damage.

## SAFETY TIPS

- Carefully read and follow all safety messages in this manual and safety signs on the unit.
- Keep safety signs in good condition and replace missing or damaged items.
- Learn how to operate the unit and how to use the controls properly.
- **Do not** let anyone operate the unit without proper training. This appliance is **not** intended for use by very young children or infirm persons without supervision. Young children should be supervised to ensure that they do not play with the appliance.
- Keep your unit in proper working condition and do not allow unauthorized modifications to the unit.

## QUALIFIED SERVICE PERSONNEL

### **WARNING:**

Only trained and certified electrical, plumbing and refrigeration technicians should service this unit. **ALL WIRING AND PLUMBING MUST CONFORM TO NATIONAL AND LOCAL CODES. FAILURE TO COMPLY COULD RESULT IN SERIOUS INJURY, DEATH OR EQUIPMENT DAMAGE.**

## SAFETY PRECAUTIONS

This unit has been specifically designed to provide protection against personal injury. To ensure continued protection observe the following:

### **WARNING:**

Disconnect power to the unit before servicing following all lock out/tag out procedures established by the user. Verify all of the power is off to the unit before any work is performed.

Failure to disconnect the power could result in serious injury, death or equipment damage.

### **CAUTION:**

Always be sure to keep area around the unit clean and free of clutter. Failure to keep this area clean may result in injury or equipment damage.

## SHIPPING AND STORAGE

### **CAUTION:**

Before shipping, storing, or relocating the unit, the unit must be sanitized and all sanitizing solution must be drained from the system. A freezing ambient environment will cause residual sanitizing solution or water remaining inside the unit to freeze resulting in damage to internal components.

## CO<sub>2</sub> (CARBON DIOXIDE) WARNING

### **DANGER:**

CO<sub>2</sub> displaces oxygen. Strict attention **MUST** be observed in the prevention of CO<sub>2</sub> gas leaks in the entire CO<sub>2</sub> and soft drink system. If a CO<sub>2</sub> gas leak is suspected, particularly in a small area, **IMMEDIATELY** ventilate the contaminated area before attempting to repair the leak. Personnel exposed to high concentrations of CO<sub>2</sub> gas experience tremors which are followed rapidly by loss of consciousness and **DEATH**.

## MOUNTING IN OR ON A COUNTER

### **WARNING:**

When installing the unit in or on a counter top, the counter must be able to support a weight in excess of **250 lbs.** to insure adequate support for the unit. **FAILURE TO COMPLY COULD RESULT IN SERIOUS INJURY, DEATH OR EQUIPMENT DAMAGE.**

**NOTE:** Many units incorporate the use of additional equipment such as icemakers. When any addition equipment is used you must check with the equipment manufacturer to determine the additional weight the counter will need to support to ensure a safe installation.

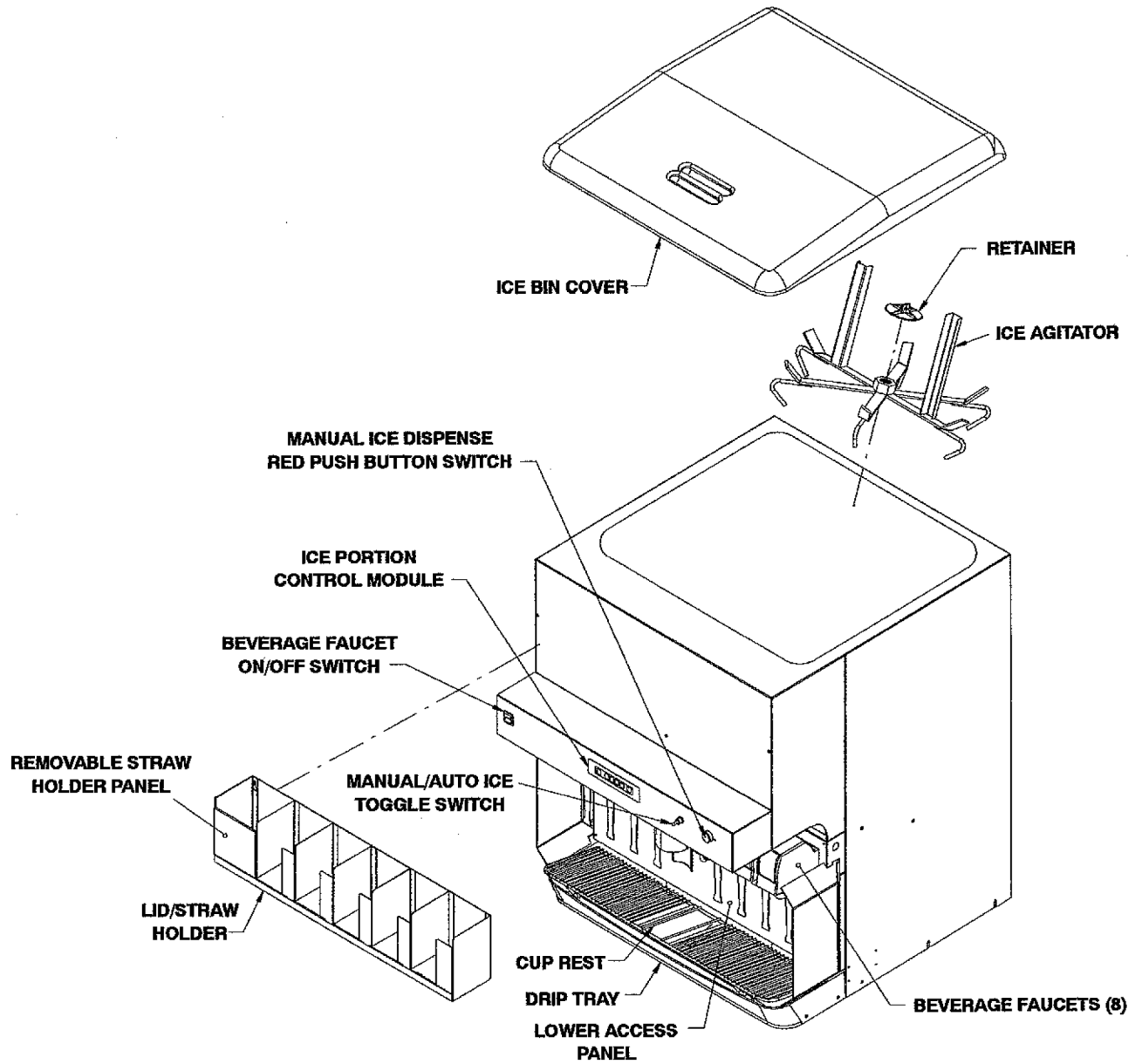

**FIGURE 1. PARTS IDENTIFICATION**

# START-UP AND OPERATING INSTRUCTIONS

## ICE DRINK DISPENSER

The ice drink dispenser shall be installed by qualified personnel following instruction given in the Installation manual part number 620916502INS. Fill the hopper with ice. Dispense several large cups of ice (approximately 20 to 30 seconds total dispensing time) to allow ice to fill the cold plate cabinet. Add ice to the hopper as necessary to refill, then replace the lid. Allow 10 to 15 minutes for the cold plate to cool down. Repeat this procedure whenever the dispenser has run out of ice. Start up the beverage system and adjust faucets to the proper brix. Contact your local syrup distributor for complete information on the beverage system.

The ice drink dispenser is designed to operate in ambient temperatures ranging from 40 to 105° F. Do not allow the unit to be stored or operated in conditions below 32° F. This could cause damage to the unit.

### CAUTION:

Dispenser cannot be used with crushed or flaked ice. Use of bagged ice which has frozen into large chunks can void warranty. The dispenser agitator is not designed to be an ice crusher. Use of large chunks of ice which “jam up” inside the hopper will cause failure if the agitator motor and damage to the hopper. If bagged ice is used, it must be carefully and completely broken into small, cube-sized pieces and left to “temper” or warm up for a minimum of 20 minutes in room temperature before loading into the dispenser hopper

In normal operation, pushing the ice dispenser mechanism will cause ice to flow from the ice chute. Ice flow will continue until the dispenser mechanism is released. Dispensing of any faucet will provide beverage of the appropriate flavor.

### WARNING:

Use caution to avoid spilling ice when filling dispenser. Clean up immediately any spilled ice from filling or operating the unit. To prevent contamination of ice, the lid must be installed on the unit at all times. **FAILURE TO CLEAN UP SPILLS COULD RESULT IN SERIOUS INJURY OR DEATH**

If the dispenser fails to dispense ice or beverage, refer to the troubleshooting section in the Installation Manual part number 620916502INS.

**NOTE: The dispenser is not designed for a wash-down environment and MUST NOT be placed in an area where a water jet could be used.**

**NOTE: This appliance is not intended for use by personnel (including children) with reduced physical, sensory or mental capabilities or lack of experience and knowledge, unless given supervision or instruction concerning use of the appliance by a person responsible for safety.**

## CONTROLS AND ELECTRICAL

### Portion Control Panel

The portion control panel on the Pro ED Fast Gate has several functions including dispensing 4 programmed ice portions for 4 cup sizes, programming, and cleaning. The portion control panel and its functionality are described in the following illustration:



### PORTION CONTROL PANEL OPERATIONS

Light Color	Explanation	Actions That Can Be Taken
Green	Normal Operation	Press any <b>CUP SIZE</b> for portioned ice. — or — Press <b>INCREASE</b> and then <b>CUP SIZE</b> for extra ice.
Green - flashing	Normal Operation Chute Refilling	Wait until chute has refilled and press desired <b>CUP SIZE</b> again.
Red then Yellow	Clean Mode	To enter Clean Mode simultaneously press <b>INCREASE</b> and <b>DECREASE</b> . Press any <b>CUP SIZE</b> to empty chute, then remove chute for cleaning. When chute is replaced, unit will automatically return to normal operation after one minute, or <b>INCREASE</b> and <b>DECREASE</b> can simultaneously be pressed 3 times.

## ICE PORTION CONTROL SET UP AND ADJUSTMENT PROCEDURE

Light Color		Explanation	Actions That Can Be Taken
Step 1. Fill the Ice Chute	Yellow Flashing	Chute Agitation Refill Time	<p>To enter Agitation Adjustment Mode simultaneously press <b>INCREASE</b> and <b>DECREASE</b> three times then press and hold <b>INCREASE</b> and <b>DECREASE</b> for 3 seconds.</p> <p>Press any <b>CUP SIZE</b> to select a preset agitation time (small=shortest time, X-Large=longest time, ect)</p> <p>To exit Agitation Refill Time Adjustment Mode simultaneously press <b>INCREASE</b> and <b>DECREASE</b>.</p> <p>NOTE: Once in a mode the light will blink to indicate the refill time: 1 blink for the shortest refill time-4 blinks for the longest refill. The factory recommendation is 2 blinks.</p> <p>NOTE: Larger ice portions require more time to refill.</p>
Step 2. Set portion level for each size cup	Yellow	Ice Portion Adjustment	<p>To enter Portion Adjustment Mode simultaneously press <b>INCREASE</b> and <b>DECREASE</b> twice.</p> <p>Press and hold <b>CUP SIZE</b> to be adjusted and while pressing <b>INCREASE</b> or <b>DECREASE</b> to change portion size (5 millisecond per pulse). NOTE: Make sure the light blinks as the buttons are pressed.</p> <p>The light will flash green for 5 seconds. While the green light is flashing the ice portion can be tested by pressing the <b>CUP SIZE</b> again.</p> <p>To exit Portion Adjustment Mode simultaneously press <b>INCREASE</b> and <b>DECREASE</b> two times.</p>
Step 3. If desired, set the extra ice portion adjustment	Red	Extra Ice Portion Adjustment	<p>To enter Extra Ice Adjustment Mode simultaneously press <b>INCREASE</b> and <b>DECREASE</b> three times.</p> <p>Press and hold the <b>CUP SIZE</b> to be adjusted and press <b>INCREASE</b> or <b>DECREASE</b> to change portion size (5 millisecond per pulse). NOTE: Make sure the light blinks as the buttons are pressed.</p> <p>To exit Extra Ice Portion Adjustment Mode simultaneously press <b>INCREASE</b> and <b>DECREASE</b>.</p>

**NOTE: Consult store manager on desired ice level in each size cup.**

### CAUTION:

The gate closes immediately when the toggle switch is moved to the auto position. **Do not place fingers or foreign objects into the ice chute when operating the toggle switch.**

## CLEANING AND MAINTENANCE INSTRUCTIONS

These instructions are used on all Cornelius ice drink dispensers. Some models may have additional cleaning requirements. Those models will have addition procedures listed later in the manual.



### WARNING:

Disconnect power to the unit before cleaning or servicing following all lock out / tag out procedures established by the user. Verify all of the power is off to the unit before performing any work.

Failure to comply could result in serious injury, death or damage to the equipment.



### CAUTION:

Do not use metal scrapers, sharp objects or abrasives on the ice storage hopper, top cover, agitator disc or exterior surfaces as damage to the unit may result. Do not use solvents or other cleaning agents as they may attack the material resulting in damage to the unit.

**Soap solution** – Use a mixture of mild detergent and warm (100° F ) potable water.

**Sanitizing Solution** – Dissolve 2 packets (4 oz) of Stera Sheen Green Label into 2 gallons of warm (80 – 100° F) potable water to ensure 200 ppm of chlorine.

### Daily Cleaning:

1. Remove cup rest from drip tray and clean with warm soapy water, rinse with clean water and allow to air dry.
2. Wipe down the exterior of the unit with warm soapy water, rinse with clean water and allow to air dry.
3. Remove valve nozzles and diffusers and wash in warm soapy water, rinse in clean water and allow to air dry.
4. Clean the interior of the ice chute using the brush provided with the unit with warm soapy water, rinse with clean water and allow to air dry.
5. Spray the ice chute inside and out with sanitizer and allow to air dry.
6. Pour warm soapy water down the drains to keep them clean and flowing smoothly.
7. Spray the nozzles and diffusers inside and outside with approved sanitizing solution, reinstall them on the valves and allow to air dry.
8. Reinstall the cup rest into the drip tray.
9. Pour all remaining sanitizer solution down the drains to help keep the drain clear.

### Daily Maintenance:

1. Check the temperature, smell and taste of the product.
2. Check the water pressure coming to the unit using the pressure gauges on the back room package.
3. Check carbonation of the drink
4. Check level of CO2 supply to the system.
5. Check the date on all of the BIB's (bags in boxes).

### Weekly Cleaning: (In addition to daily procedures)

Remove the ice chute cover and clean it along with the back half with warm soapy using the brush provided with the unit. Rinse with clean water and reinstall on the unit. Spray the ice chute assembly with approved sanitizer allowing it to air dry.

### Monthly Cleaning: (In addition to daily and weekly procedures)

1. Flush and sanitize all syrup lines as well as all of the syrup connectors. (See the sanitize syrup lines section shown later in this manual).

2. Remove ice from hopper and clean and sanitize the hopper. (See the Cleaning the interior surfaces section shown later in this manual).
3. While cleaning the hopper use the brush provided with the unit to clean the cold plate surface. To accomplish this, the brush needs to be extended through the opening in the bottom of the hopper.

### **Yearly Maintenance:**

Have the water pump and check valve inspected and cleaned by a qualified service technician.

Have the CO2 gas check valve inspected and cleaned by a qualified service technician.

Remove the unit's splash and cold plate cover to clean and sanitize the cold plate surface. (See the cleaning the cold plate section shown later in this manual).

### **Cleaning Interior Surfaces (Monthly Cleaning)**

#### **⚠ CAUTION:**

When pouring liquid into the hopper, do not exceed the rate of 1/2 gallon per minute. Pouring more liquid into the hopper could result in an overflow situation may result in injury or damage to the equipment.

1. Remove agitator assembly.
2. Using a nylon bristle brush or sponge, clean the interior of the hopper, top cover and agitator assembly with soap solution. Thoroughly rinse the hopper, cover and agitator surfaces with clean potable water.
3. Reassemble agitator assembly. Take special care to ensure that the thumbscrew is tight.
4. Using a mechanical spray bottle filled with sanitizing solution, spray the entire interior and agitator assembly. Allow to air dry.
5. Remove merchandiser and ice chute cover from unit.
6. With a nylon bristle brush or sponge, clean the inside of the ice chute, gasket, and cover with soap solution and rinse thoroughly to remove all traces of detergent.
7. Reassemble ice chute assembly.
8. Using a mechanical spray bottle filled with sanitizing solution, spray the inside of the ice chute. Allow to air dry.
9. Reinstall merchandiser.

### **Cold Plate (Yearly Maintenance)**

1. Remove splash panel.
2. Remove or move the plastic cold plate cover to expose the cold plate.
3. Locate and remove any debris from the drain trough. Check that the drain holes are not clogged.
4. Pour small amount of soap solution through cold plate openings in hopper.
5. Using a cloth, wash down the surfaces of the cold plate and plastic cover with soap solution.
6. Install and properly position the access covers on the cold plate.
7. Install the splash panel in the reverse order it was removed.
8. Rinse cold plate surface by pouring potable water through hopper openings.

### **Dispensing Valves: ( Daily Cleaning)**

Refer to addendum supplied with the unit that is applicable to the manufacturer of the valves installed on the unit.

### **Product Tubing (Monthly Cleaning)**

**IMPORTANT: Only trained and qualified persons should perform these cleaning and sanitizing procedures.**

#### **Sanitize Pre-Mix And Post-Mix Tank System**

1. Remove all the quick disconnects from all the tanks. Fill a suitable pail or bucket with soap solution.
2. Submerge all disconnects (gas and liquid) in the soap solution and then clean them using a nylon bristle brush. **(Do not use a wire brush)**. Rinse with clean water.
3. Prepare sanitizing solution and using a mechanical spray bottle, spray the disconnects. Allow to air dry.
4. Using a clean, empty tank, prepare five (5) gallons of the sanitizing solution. Rinse the tank disconnects with approximately 9 oz. of the sanitizing solution. Close the tank.
5. Prepare cleaning tank by filling clean five (5) gallon tank with a mixture of mild detergent and potable water (120°F).
6. Connect a gas disconnect to the tank and then apply one of the product tubes to the cleaning tank. Operate the appropriate valve until liquid dispensed is free of any syrup.
7. Disconnect cleaning tank and hook up sanitizing tank to syrup line and CO<sub>2</sub> system.
8. Energize beverage faucet until chlorine sanitizing solution is dispensed through the faucet. Flush at least two (2) cups of liquid to ensure that the sanitizing solution has filled the entire length of the syrup tubing.
9. Allow sanitizer to remain in lines for fifteen (15) minutes.
10. Repeat the step above, applying a different product tube each time until all tubes are filled with the sanitizing solution.
11. Remove the nozzle and syrup diffuser and clean them in a mild soap solution. Rinse with clean water and reassemble the nozzle and syrup diffuser on the valve.
12. Rinse the parts in clean water, reassemble the valve and reconnect it to the dispenser.
13. Discard the tank of sanitizing solution and reconnect the product syrup tanks. Operate the valves until all sanitizer has been flushed from the system and only product syrup is flowing.

#### **Sanitize syrup lines, BIB Systems**

1. Remove all the quick disconnects from all the BIB containers.
2. Fill a suitable pail or bucket with soap solution.
3. Submerge all disconnects (gas and liquid) in the soap solution and then clean them using a nylon bristle brush. **(Do not use a wire brush)**. Rinse with clean water.
4. Using a plastic pail, prepare approximately five (5) gallons of sanitizing solution.
5. Rinse the BIB disconnects in the sanitizing solution.
6. Sanitizing fittings must be attached to each BIB disconnect. If these fittings are not available, the fittings from empty BIB bags can be cut from the bags and used. These fittings open the disconnect so the sanitizing solution can be drawn through the disconnect.
7. Place all the BIB disconnects into the pail of sanitizing solution. Operate all the valves until the sanitizing solution is flowing from the valve. Allow sanitizer to remain in lines for fifteen (15) minutes.
8. Remove the nozzle and syrup diffuser from each valve and clean them in a soap solution. Rinse with clean water and reassemble the nozzle and syrup diffuser to the valve.
9. Remove the sanitizing fittings from the BIB disconnects and connect the disconnects to the appropriate BIB container. Operate the valves until all sanitizer has been flushed from the system and syrup is flowing freely.

## Replenishing CO<sub>2</sub> Supply (As Required)

**NOTE:**When indicator on the 1800-psi gage is in the shaded (“change CO<sub>2</sub> cylinder”) portion of the dial, CO<sub>2</sub> cylinder is almost empty and should be changed.

1. Fully close (clockwise) the CO<sub>2</sub> cylinder valve.
2. Slowly loosen the CO<sub>2</sub> regulator assembly coupling nut allowing CO<sub>2</sub> pressure to escape, then remove the regulator assembly from the empty CO<sub>2</sub> cylinder.
3. Unfasten safety chain and remove the empty CO<sub>2</sub> cylinder

### **WARNING:**

To avoid personnel injury and/or property damage, always secure the CO<sub>2</sub> cylinder with a safety chain to prevent it from falling over. Should the valve become accidentally damaged or broken off, a CO<sub>2</sub> regulator can cause serious personnel injury or death could occur.

4. Position the full CO<sub>2</sub> cylinder and secure with a safety chain.
5. Make sure gasket is in place inside the CO<sub>2</sub> regulator assembly coupling nut, then install the regulator assembly on the CO<sub>2</sub> cylinder.
6. Open (counterclockwise) the CO<sub>2</sub> cylinder valve slightly to allow the lines to slowly fill with gas, then open the valve fully to back-seat the valve (back-seating the valve prevents gas leakage around the valve shaft).
7. Check CO<sub>2</sub> connections for leaks. Tighten any loose connections.

# TROUBLESHOOTING

**IMPORTANT:** Only qualified personnel should service internal components or electrical wiring.

**⚠ WARNING:**

If repairs are to be made to the beverage system, remove quick disconnects from the applicable product tank, then relieve the system pressure before proceeding. If repairs are to be made to the CO2 system, stop dispensing, shut off the CO2 supply, then relieve the system pressure before proceeding. If repairs are to be made to the ice dispensing system, make sure electrical power is disconnected from the unit.

Trouble	Probable Cause	Remedy
<b>NOTE: Should your unit fail to operate properly, check that there is power to the unit and that the hopper contains ice. If the unit does not dispense, check the following chart under the appropriate symptom(s) to aid in locating the defect.</b>		
BLOWN FUSE OR CIRCUIT BREAKER.	A. Short circuit in wiring (115V circuit).	A. Replace defective wiring.
	B. Defective agitator motor.	B. Replace agitator motor.
SLUSHY ICE. WATER IN HOPPER	A. Blocked drain.	A. Open-up/flush out drain.
	B. Unit not level.	B. Level unit.
	C. Poor ice quality due to water quality or ice maker problems.	C. Install water filter system. For icemaker problems, consult icemaker manual.
	D. Improper use of flaked ice.	D. Replaced flaked ice with "cube style ice (see page 2, Unit Description).
BEVERAGES DO NOT DISPENSE.	A. No 24 volt power to faucets.	A. Check that beverage switch is "on". Check 24V transformers.
	B. No CO2 pressure.	B. Check CO2 regulator. Check CO2 tank pressure.
BEVERAGES TOO SWEET.	A. Carbonator not working.	A. Check carbonator.
	B. No CO2 pressure in carbonator.	B. Check CO2 regulator. Check CO2 tank pressure.
	C. Faucet brix requires adjusting.	C. Brix Faucet.
BEVERAGES NOT SWEET ENOUGH.	A. Empty syrup tank.	A. Refill syrup tank.
	B. Faucet Brix requires adjusting.	B. Brix Faucet.
BEVERAGES NOT COLD (UNITS WITH BUILD-IN COLD PLATE).	A. Unit standing with no ice in hopper - no ice in cold plate cabinet.	A. Refill hopper with ice.
<b>NOTE: Contact your local syrup or beverage equipment distributor for additional information and trouble shooting of beverage system.</b>		
NO ICE DISPENSED FROM ICE PORTION CONTROLLER	A. Insufficient ice supply in ice bin.	A. Replenish ice supply as required.
	B. Ice in ice bin bridged (stuck together).	B. Gently tap on ice to break it loose.
	C. No electrical power to dispenser.	C. Plug in dispenser power cord, or check fuse or circuit breaker.

Trouble	Probable Cause	Remedy
NO ICE DISPENSED FROM ICE PORTION CONTROLLER (Continued)	D. Insufficient or no CO2 supply to dispenser.	D. Restore CO2 supply to dispenser.
	E. Ice chute cover not properly installed.	E. Make sure that cover is "snapped" into place.
	F. Defective ice chute interlock switch.	F. Replace interlock switch.
	G. Defective interlock relay.	G. Replace relay.
	H. Defective 24V transformer.	H. Replace transformer.
	I. Defective portion controller.	I. Replace controller.
	J. Defective ice gate cylinder.	J. Replace cylinder.
	K. Defective ice gate solenoid valve.	K. Replace solenoid valve.
	L. Agitation relay wiring incorrect.	L. Red wire should be connected to "+" terminal (#3) of relay coil.
	M. Defective agitation relay.	M. Replace relay.
N. Defective agitator motor start capacitor or start relay.	N. Replace defective component	
NO ICE DISPENSED FROM MANUAL ICE DISPENSE PUSHBUTTON SWITCH	A. Manual/Auto toggle switch in "Auto" position.	A. Move toggle switch to "Manual" position.
	B. Insufficient or no CO2 supply to dispenser.	B. Restore CO2 supply to dispenser.
	C. Defective 24VAC transformer.	C. Replace Transformer.
	D. Defective manual override solenoid valve.	D. Replace valve.
	E. Defective manual ice dispense pushbutton switch.	E. Replace switch.
	F. Defective agitator motor or start capacitor or start relay.	F. Replace defective component.
	G. Defective ice gate cylinder.	G. Replace cylinder.
ICE DISPENSING DURING AUTOMATIC AGITATION	A. Manual/Auto toggle switch in "manual" position.	A. Move toggle switch to "auto" position.
	B. Defective ice gate cylinder.	B. Replace cylinder.
	C. Defective ice gate solenoid valve.	C. Replace valve.
	D. Defective portion controller.	D. Replace controller.



**Cornelius Inc.**  
**[www.cornelius.com](http://www.cornelius.com)**